

Tog-L-Loc[®] Clinch Tooling

Standard, Semi-Standard and Special Tog-L-Loc Solutions*

NOTE: Not all of the Tog-L-Loc[®] components shown in this catalog are stocked by BTM. Please contact the BTM Sales department with your delivery requirements.

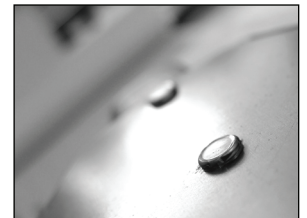
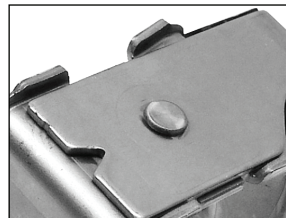

Features 3.0, 3.8, 4.6, 5.5, 6.4, and 7.6mm Tooling

Two Bladed and Three Bladed Elastomer Dies

Whistle Notch Flat and Ball Lock Punches



BTM[®]
COMPANY

www.btmcomp.com

810-364-4567

Fastening without Fasteners

BTM's patented Tog-L-Loc® sheet metal joining system is the simple solution for fastening plain or coated sheet metals. Tog-L-Loc® forms a strong, leakproof "button" headed joint without welding or riveting in almost any combination of ductile sheet metals. The Tog-L-Loc® system is widely used in the manufacture of automobiles, appliances, furniture, electrical products, building supplies, and more.

For information on how to apply this tooling, or to inquire about other types of sheet metal clinch tooling, contact BTM Corporation.

NOTE: 940 Series tooling is not included in this catalog. Please reference BTM's "Tog-L-Loc® 940 Series Tooling" catalog for more information.

TOG-L-LOC® PROCESS

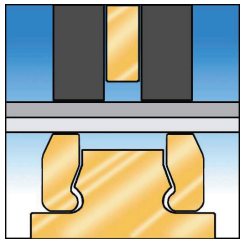

CLAMPS

The first step in the Tog-L-Loc® process involves clamping of the material with a punch side stripper.

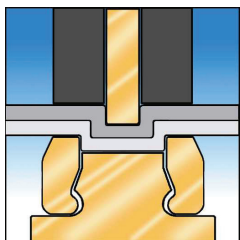

DRAWS

Next, the punch draws the material into the die.

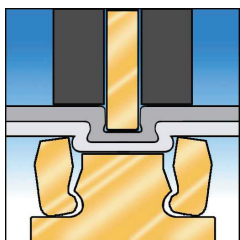

LOCKS

As the material flows into the die, the die blades expand, allowing the metal to flow into a strong interlock.

A few examples of parts clinched using the Tog-L-Loc® sheet metal joining system.



Gas Tank Straps

Joined in a progressive die.



Automotive Hood

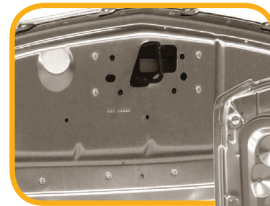

Galvanized Duct

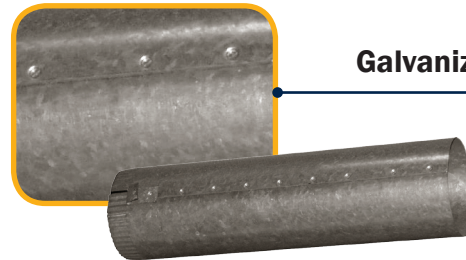

Pre-Painted Air Conditioning Cabinet



TOG-L-LOC® DIE COMPARISON

DIES FEATURED IN THIS CATALOG



Three Bladed Elastomer Dies

These dies are ideal when the die guarding can be modified to incorporate contour features in a part.



Two Bladed Dies

Ideal for very tight joining locations up against a flange, where the blades can operate parallel.

OTHER TOG-L-LOC® DIES

940 Series Dies



940 Dies feature a built in die shield that surrounds an elastomer ring (or a canted coil spring) and three die blades.

Contact BTM for more information.

BEFORE YOU ORDER

Follow these steps to ensure your satisfaction with Tog-L-Loc®:

1. Submit a sample of your part and or material to the BTM sample department. A "Sample Data Sheet" will be used to record what tooling was used to make your sample, as well as the resulting shear and peel strengths.
2. Test your sample
3. Upon your approval, contact the BTM application engineering department and we will help you select the correct punch, die, stripper, and holders. This catalog will be used as a reference.
4. Order the required Tog-L-Loc® solution for your application.

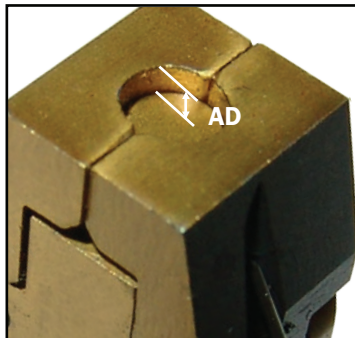

Anvil Depth

The Anvil Depth is the distance from the anvil to the top of the die blades. The correct anvil depth for an application is determined through testing and/or surrogate joint data at BTM, not by material thickness.

AD	Standard	Aluminum
.020	711500BE	760100BE

Standard Die (Contact BTM for compatibility.)
Dies intended for use with Aluminum.

Contact BTM to ensure that you order the correct tooling configuration for the material that you are joining.

SAFETY NOTE

It is the customer and/or user's responsibility to provide proper safety controls and/or guarding when a pinch point is present.

Tog-L-Loc® Tooling Terminology

Whistle Notch Flat Punch Holders

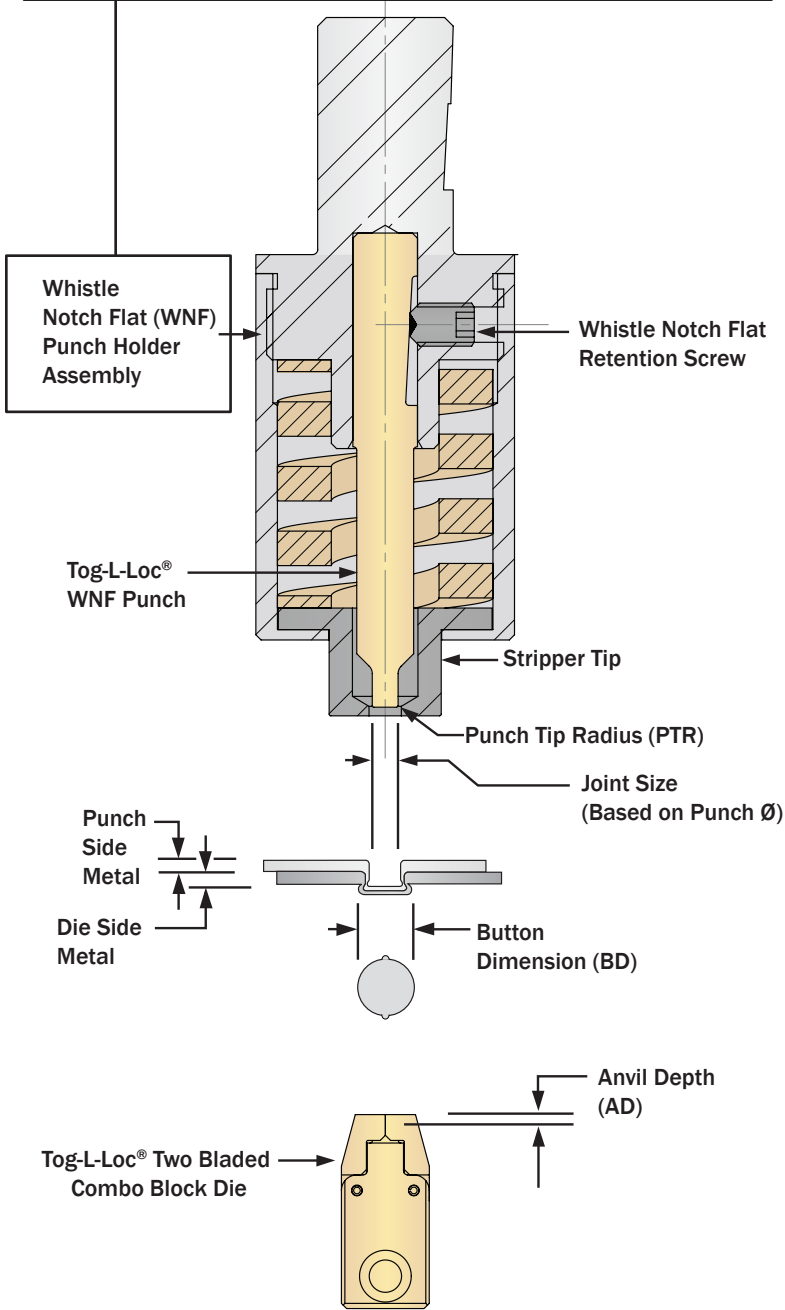
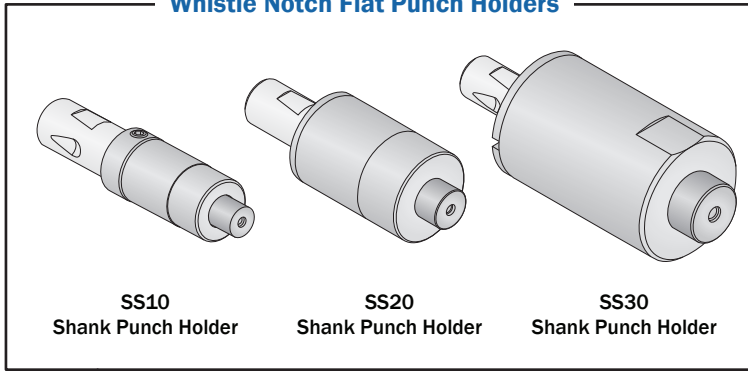

Ball Lock Punch Holders

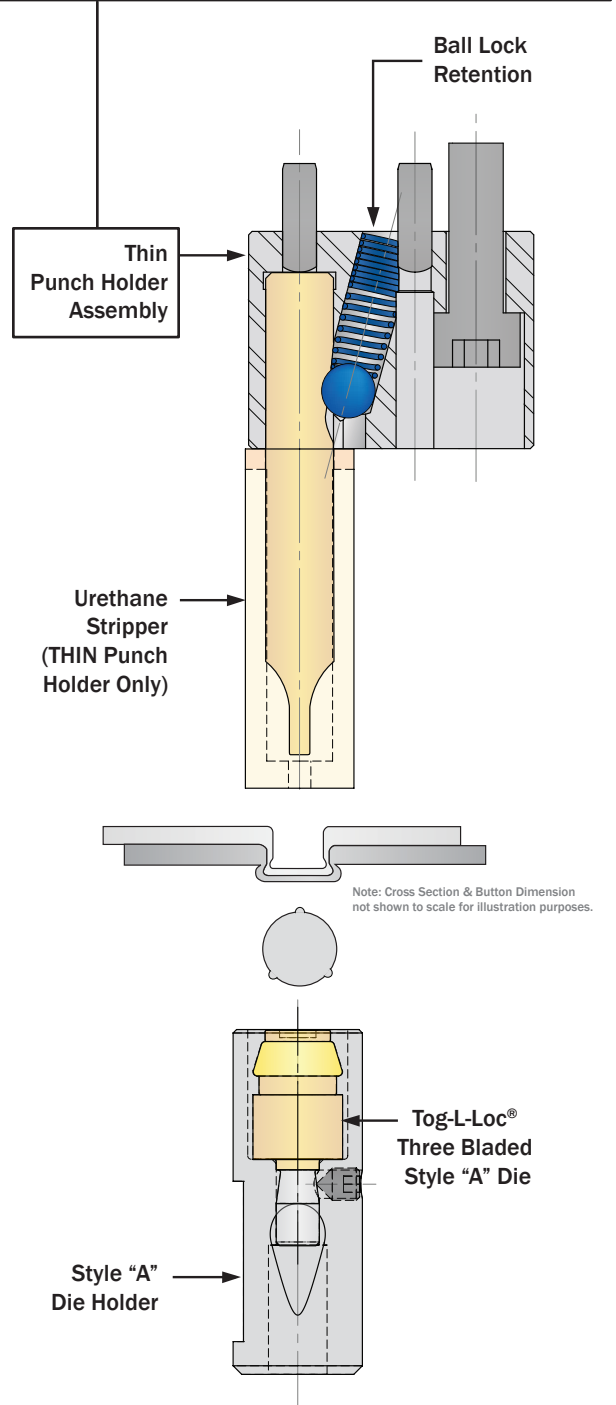
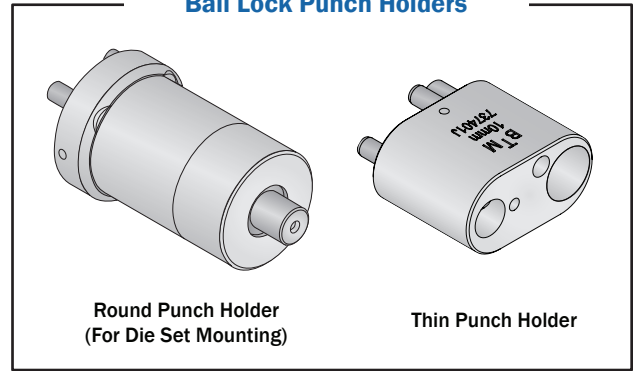

TABLE OF CONTENTS

WHISTLE NOTCH FLAT (WNF) PUNCHES

3.0	6
3.8	6
4.6	6
5.5	7
6.4	7
7.6	7

WNF PUNCH ASSEMBLIES AND HOLDERS

SS10 Metric Shank Punch Holder	8
SS10 Imperial Shank Punch Holder	9
SS20 Metric Shank Punch Holder	10
SS20 Imperial Shank Punch Holder	11
SS30 Imperial Shank Punch Holder	12-13

BALL LOCK PUNCHES

3.0	14
4.6	14
6.4	15
7.6	15

BALL LOCK PUNCH ASSEMBLIES AND HOLDERS

Round Die Set Punch Holder	16
THIN Punch Holder	17

3.0 TOG-L-LOC® DIES

Three Bladed Elastomer Dies	18
Two Bladed Dies	19

3.8 TOG-L-LOC® DIES

Three Bladed Elastomer Dies	20
Two Bladed Die	21

4.6 TOG-L-LOC® DIES

Three Bladed Elastomer Dies	22
Two Bladed Dies	23

5.5 TOG-L-LOC® DIES

Three Bladed Elastomer Dies	24
Two Bladed Die	25

6.4 TOG-L-LOC® DIES

Three Bladed Elastomer Dies	26-27
-----------------------------------	-------

TOG-L-LOC® DIE HOLDERS

Three Bladed Elastomer Dies	28-29
-----------------------------------	-------

TOG-L-LOC® DIE MOUNTING	30-35
-------------------------------	-------

Tog-L-Loc® Whistle Notch Flat (Set Screw Retention) Punches

NOTE: Whistle Notch Flat Punch Holders come complete with a punch.
 You do not need to order a punch separately if you are ordering a Whistle Notch Flat punch holder.

3.0 Whistle Notch Flat Punch

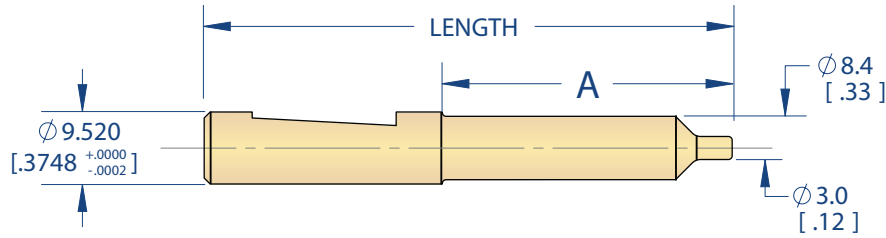

Punch Length	PTR	"A"	Order No.
69.85 [2.750"]	.010	38.4 [1.51"]	004933
	.020	38.4 [1.51"]	006011
95.25 [3.750"]	.010	63.75 [2.51"]	006622
	.020	63.75 [2.51"]	006623

Compatible Holder Styles

Shank Mounting (SS10) p.8-9

3.8 Whistle Notch Flat Punch

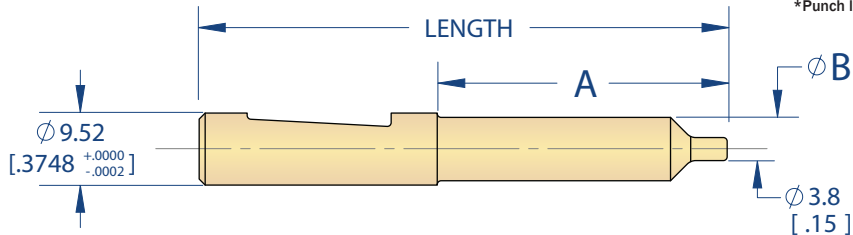

Punch Length	PTR	"A"	"B"	Order No.
69.85 [2.750"]	.010	38.4 [1.51"]	Ø8.4 [.33"]	797001A
	.020	38.4 [1.51"]	Ø8.4 [.33"]	797001B
95.25 [3.750"]	.010	N/A*	Ø9.52 [.37"]	797001C
	.020	N/A*	Ø9.52 [.37"]	797001D

*Punch length maintains full diameter on 95.25 [3.75"] punch.

Compatible Holder Styles

Shank Mounting (SS20) p. 10-11

4.6 Whistle Notch Flat Punch

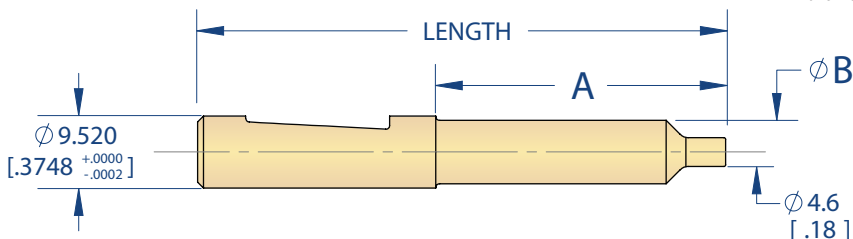

Punch Length	PTR	"A"	"B"	Order No.
69.85 [2.750"]	.010	38.4 [1.51"]	Ø8.4 [.33"]	002798
	.020	38.4 [1.51"]	Ø8.4 [.33"]	002992
95.25 [3.750"]	.010	N/A*	Ø9.52 [.37"]	006624
	.020	N/A*	Ø9.52 [.37"]	006636

*Punch length maintains full diameter on 95.25 [3.75"] punch.

Compatible Holder Styles

Shank Mounting (SS10) p.9
 (SS20) p.10-11

5.5 Whistle Notch Flat Punch

Punch Length	PTR	"A"	"B"	Order No.
69.85 [2.750"]	.010	38.4 [1.51"]	Ø8.4 [.33"]	018934
	.020	38.4 [1.51"]	Ø8.4 [.33"]	018935
95.25 [3.750"]	.010	N/A*	Ø9.52 [.37"]	018936
	.020	N/A*	Ø9.52 [.37"]	018937

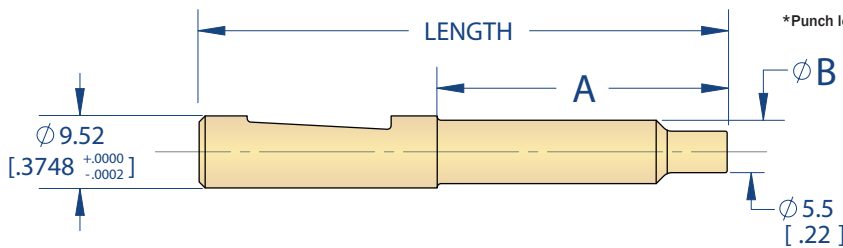

*Punch length maintains full diameter on 95.25 [3.75"] punch.

Compatible Holder Styles

Shank Mounting (SS20) p.10-11

6.4 Combined Whistle Notch Flat & Ball Lock Punch

Punch Length	PTR	Order No.
95.25 [3.750"]	.010	014707
	.020	012121
120.65 [4.750"]	.010	014708
	.020	013905

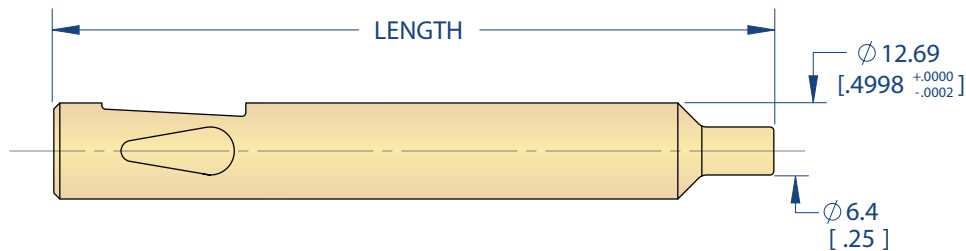

Compatible Holder Styles

Shank Mounting (SS20) p.10-11
 (SS30) p.12-13

7.6 Combined Whistle Notch Flat & Ball Lock Punch

Punch Length	PTR	Order No.
95.25 [3.750"]	.010	768001A
	.020	768001B
120.65 [4.750"]	.010	768001C
	.020	768001D

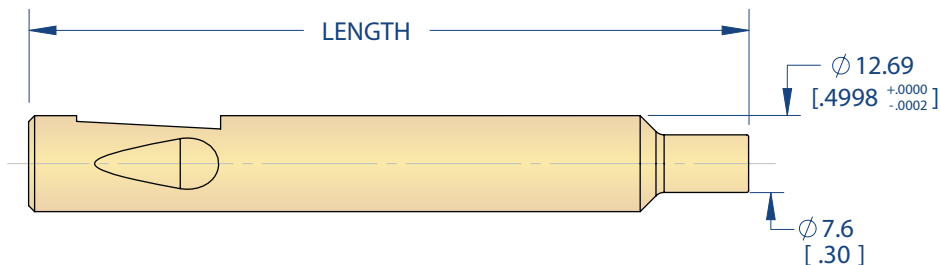

Tog-Loc® SS10 Shank METRIC Mounting for Whistle Notch Flat Punches

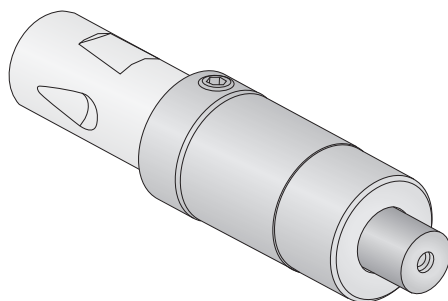

ASSEMBLY INCLUDES:

- ① One (1) Punch Holder
- ② One (1) Stripper Spring
- ③ One (1) Stripper Can
- ④ One (1) Punch Retaining Screw
- ⑤ One (1) Tog-Loc® Punch
- ⑥ One (1) Stripper Tip

3.0 Tooling

Punch Length	PTR	A	B	Order No.
69.85 [2.750"]	.010	101.60 [4.000"]	Ø9.5 (.38")	018879
	.020	101.60 [4.000"]	Ø9.5 (.38")	018880
95.25 [3.750"]	.010	127 [5.000"]	Ø35.0 (1.38")	018881
	.020	127 [5.000"]	Ø35.0 (1.38")	018882

PTR = Punch Tip Radius

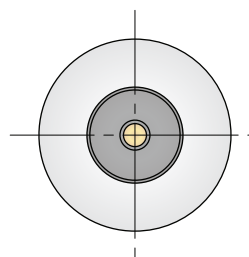
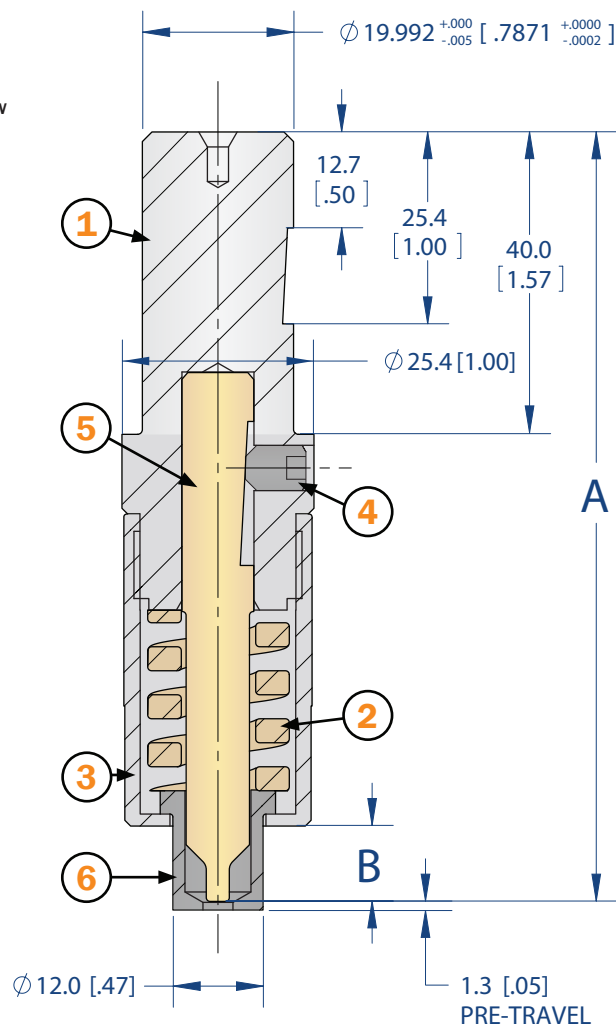

Tog-L-Loc® SS10 Shank IMPERIAL Mounting for Whistle Notch Flat Punches

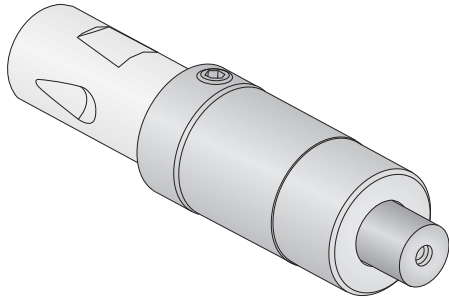

ASSEMBLY INCLUDES:

- ① One (1) Punch Holder
- ② One (1) Stripper Spring
- ③ One (1) Stripper Can
- ④ One (1) Punch Retaining Screw
- ⑤ One (1) Tog-L-Loc® Punch
- ⑥ One (1) Stripper Tip

3.0 Tooling

Punch Length	PTR	A	B	C	Order No.
69.85 [2.750"]	.010	101.60 [4.000"]	Ø9.5 [.38"]	Ø12.0 [.47"]	006644
	.020	101.60 [4.000"]	Ø9.5 [.38"]	Ø12.0 [.47"]	006646
95.25 [3.750"]	.010	127.00 [5.000"]	Ø35.0 [1.38"]	Ø12.0 [.47"]	006645
	.020	127.00 [5.000"]	Ø35.0 [1.38"]	Ø12.0 [.47"]	006647

PTR = Punch Tip Radius

4.6 Tooling

Punch Length	PTR	A	B	C	Order No.
69.85 [2.750"]	.010	101.60 [4.000"]	Ø9.5 [.38"]	Ø16.5 (.65")	006746
	.020	101.60 [4.000"]	Ø9.5 [.38"]	Ø16.5 (.65")	006748
95.25 [3.750"]	.010	127.00 [5.000"]	Ø35.0 [1.38"]	Ø16.5 (.65")	006747
	.020	127.00 [5.000"]	Ø35.0 [1.38"]	Ø16.5 (.65")	006749

PTR = Punch Tip Radius

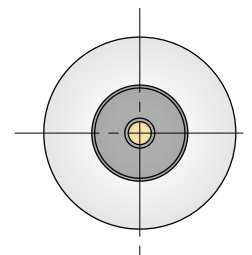
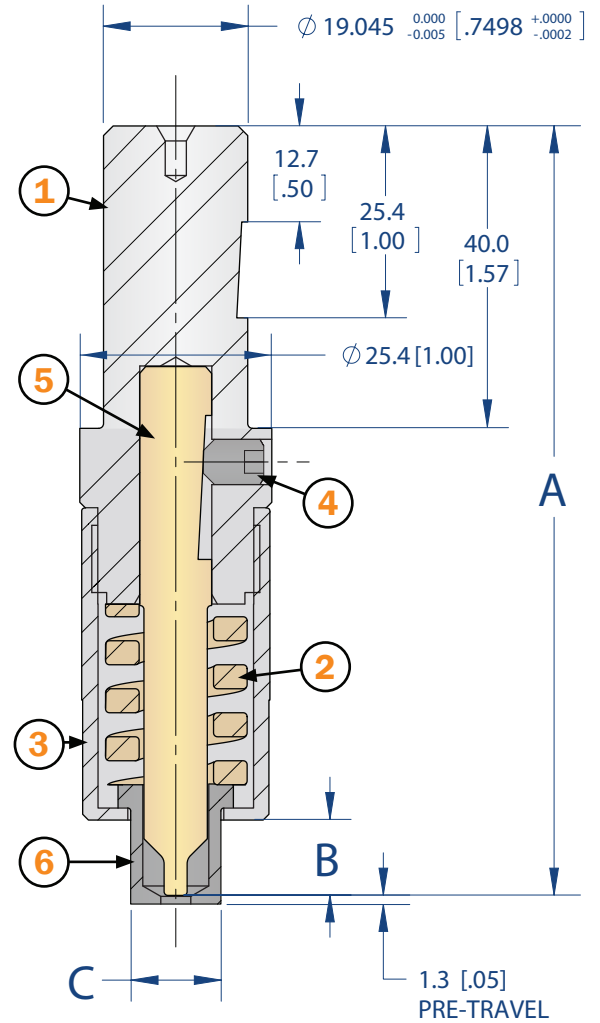

Tog-L-Loc® SS20 Shank METRIC Mounting for Whistle Notch Flat Punches

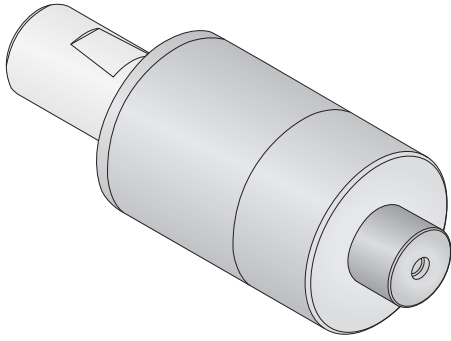

ASSEMBLY INCLUDES:

- ① One (1) Punch Holder
- ② One (1) Stripper Spring
- ③ One (1) Stripper Can
- ④ One (1) Punch Retaining Screw Assembly
- ⑤ One (1) Tog-L-Loc® Punch
- ⑥ One (1) Stripper Tip

3.8 Tooling

Punch Length	PTR	A	B	C	Order No.
69.85 [2.750"]	.010	101.6 [4.000"]	9.5 [.38"]	Ø16.5 [.65"]	797000E
	.020	101.6 [4.000"]	9.5 [.38"]	Ø16.5 [.65"]	797000F
95.25 [3.750"]	.010	127.0 [5.000"]	35 [1.38"]	Ø16.5 [.65"]	797000G
	.020	127.0 [5.000"]	35 [1.38"]	Ø16.5 [.65"]	797000H

PTR = Punch Tip Radius

4.6 Tooling

Punch Length	PTR	A	B	C	Order No.
69.85 [2.750"]	.010	101.6 [4.000"]	9.5 [.38"]	Ø16.5 [.65"]	021745
	.020	101.6 [4.000"]	9.5 [.38"]	Ø16.5 [.65"]	021746
95.25 [3.750"]	.010	127.0 [5.000"]	35 [1.38"]	Ø16.5 [.65"]	021747
	.020	127.0 [5.000"]	35 [1.38"]	Ø16.5 [.65"]	021748

PTR = Punch Tip Radius

5.5 Tooling

Punch Length	PTR	A	B	C	Order No.
69.85 [2.750"]	.010	101.6 [4.000"]	9.5 [.38"]	Ø19.1 [.75"]	PD244800A
	.020	101.6 [4.000"]	9.5 [.38"]	Ø19.1 [.75"]	PD244800B
95.25 [3.750"]	.010	127.0 [5.000"]	35 [1.38"]	Ø19.1 [.75"]	PD244800C
	.020	127.0 [5.000"]	35 [1.38"]	Ø19.1 [.75"]	PD244800D

PTR = Punch Tip Radius

6.4 Tooling

Punch Length	PTR	A	B	C	Order No.
95.25 [3.750"]	.010	127.0 [5.000"]	29.0 [1.14"]	Ø16.0 [.63"]	020533
	.020	127.0 [5.000"]	29.0 [1.14"]	Ø16.0 [.63"]	020534
120.65 [4.750"]	.010	137.0 [5.394"]	39.0 [1.54"]	Ø16.0 [.63"]	021478
	.020	137.0 [5.394"]	39.0 [1.54"]	Ø16.0 [.63"]	021479

PTR = Punch Tip Radius

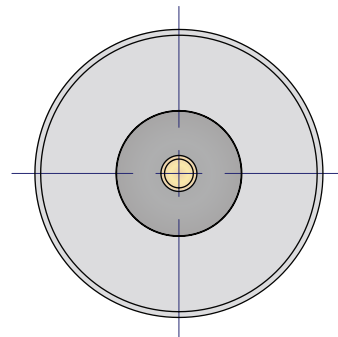
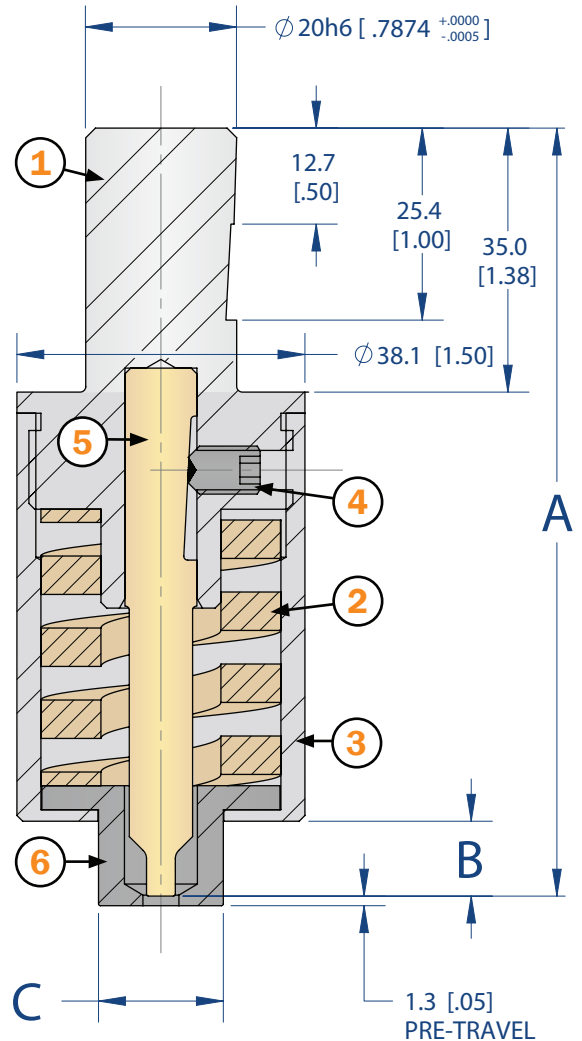

Tog-L-Loc® SS20 Shank IMPERIAL Mounting for Whistle Notch Flat Punches

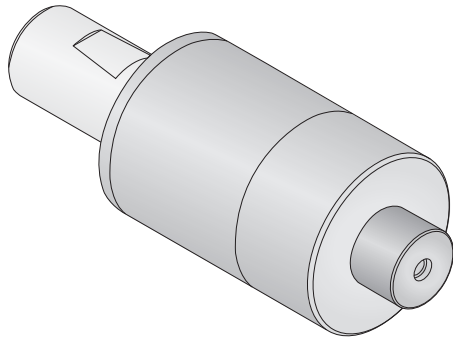

ASSEMBLY INCLUDES:

- ① One (1) Punch Holder
- ② One (1) Stripper Spring
- ③ One (1) Stripper Can
- ④ One (1) Punch Retaining Screw Assembly
- ⑤ One (1) Tog-L-Loc® Punch
- ⑥ One (1) Stripper Tip

3.8 Tooling

Punch Length	PTR	A	B	C	Order No.
69.85 [2.750"]	.010	101.6 [4.000"]	9.5 [.38"]	Ø16.5 [.65"]	797000A
	.020	101.6 [4.000"]	9.5 [.38"]	Ø16.5 [.65"]	797000B
95.25 [3.750"]	.010	127.0 [5.000"]	35.0 [1.38"]	Ø16.5 [.65"]	797000C
	.020	127.0 [5.000"]	35.0 [1.38"]	Ø16.5 [.65"]	797000D

PTR = Punch Tip Radius

4.6 Tooling

Punch Length	PTR	A	B	C	Order No.
69.85 [2.750"]	.010	101.6 [4.000"]	9.5 [.38"]	Ø16.5 [.65"]	015405
	.020	101.6 [4.000"]	9.5 [.38"]	Ø16.5 [.65"]	015406
95.25 [2.750"]	.010	127.0 [5.000"]	35.0 [1.38"]	Ø16.5 [.65"]	015408
	.020	127.0 [5.000"]	35.0 [1.38"]	Ø16.5 [.65"]	015409

PTR = Punch Tip Radius

5.5 Tooling

Punch Length	PTR	A	B	C	Order No.
69.85 [2.750"]	.010	101.6 [4.000"]	9.5 [.38"]	Ø19.1 [.75"]	PD244600A
	.020	101.6 [4.000"]	9.5 [.38"]	Ø19.1 [.75"]	PD244600B
95.25 [3.150"]	.010	127 [5.000"]	35.0 [1.38"]	Ø19.1 [.75"]	PD244600C
	.020	127 [5.000"]	35.0 [1.38"]	Ø19.1 [.75"]	PD244600D

PTR = Punch Tip Radius

6.4 Tooling

Punch Length	PTR	A	B	C	Order No.
69.85 [2.750"]	.010	101.6 [4.000"]	9.5 [.38"]	Ø27.0 [1.06"]	015369
	.020	101.6 [4.000"]	9.5 [.38"]	Ø27.0 [1.06"]	013737
95.25 [3.750"]	.010	127 [5.000"]	35.0 [1.38"]	Ø27.0 [1.06"]	015370
	.020	127 [5.000"]	35.0 [1.38"]	Ø27.0 [1.06"]	015371

PTR = Punch Tip Radius

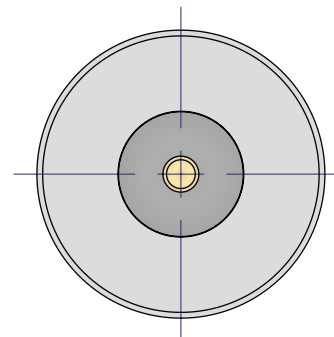
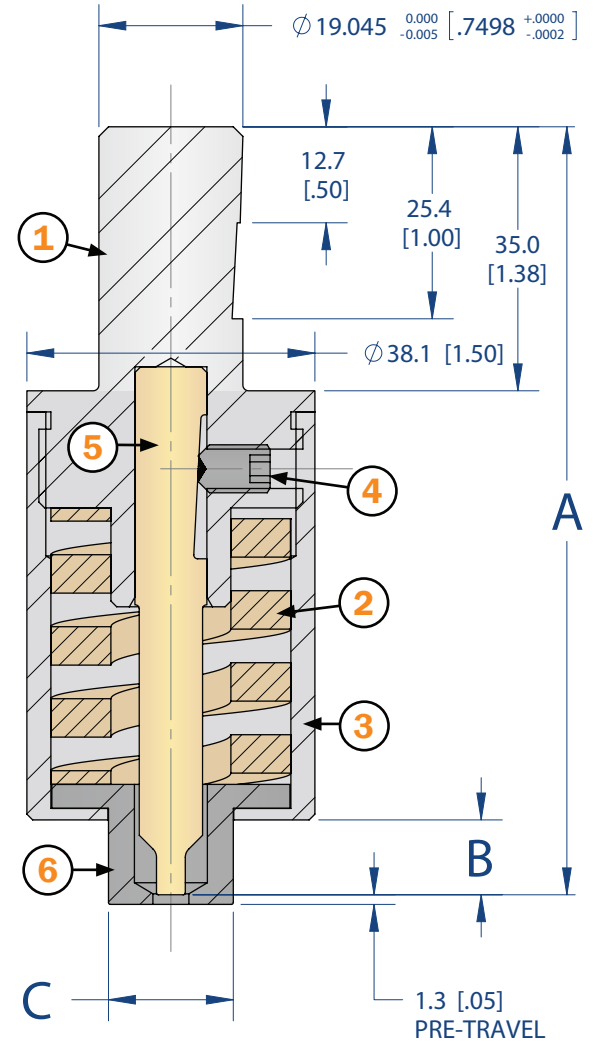

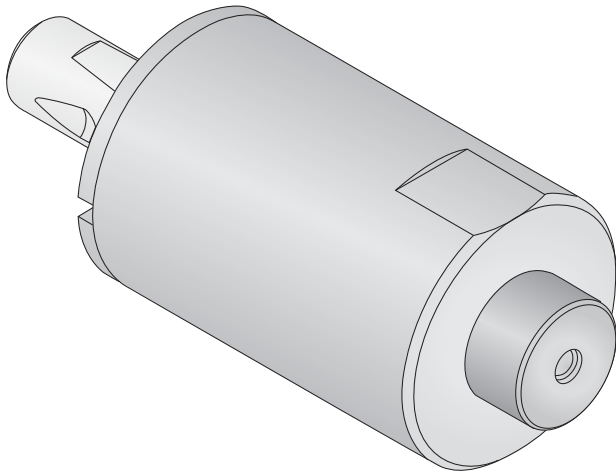

ASSEMBLY INCLUDES:

- ① One (1) Punch Holder
- ② One (1) Stripper Spring
- ③ One (1) Stripper Can
- ④ One (1) Punch Retaining Screw Assembly
- ⑤ One (1) Tog-L-Loc® Punch
- ⑥ One (1) Stripper Tip

6.4 Tooling

Punch Length	PTR	A	B	C	BTM Order No.
95.25 [3.750"]	.010	139.7 [5.500"]	12.7 [.50"]	Ø27.0 [1.06"]	015374
	.020	139.7 [5.500"]	12.7 [.50"]	Ø27.0 [1.06"]	013732
120.65 [4.750"]	.010	165.1 [6.500"]	38.1 [1.50"]	Ø27.0 [1.06"]	015375
	.020	165.1 [6.500"]	38.1 [1.50"]	Ø27.0 [1.06"]	015376

PTR = Punch Tip Radius

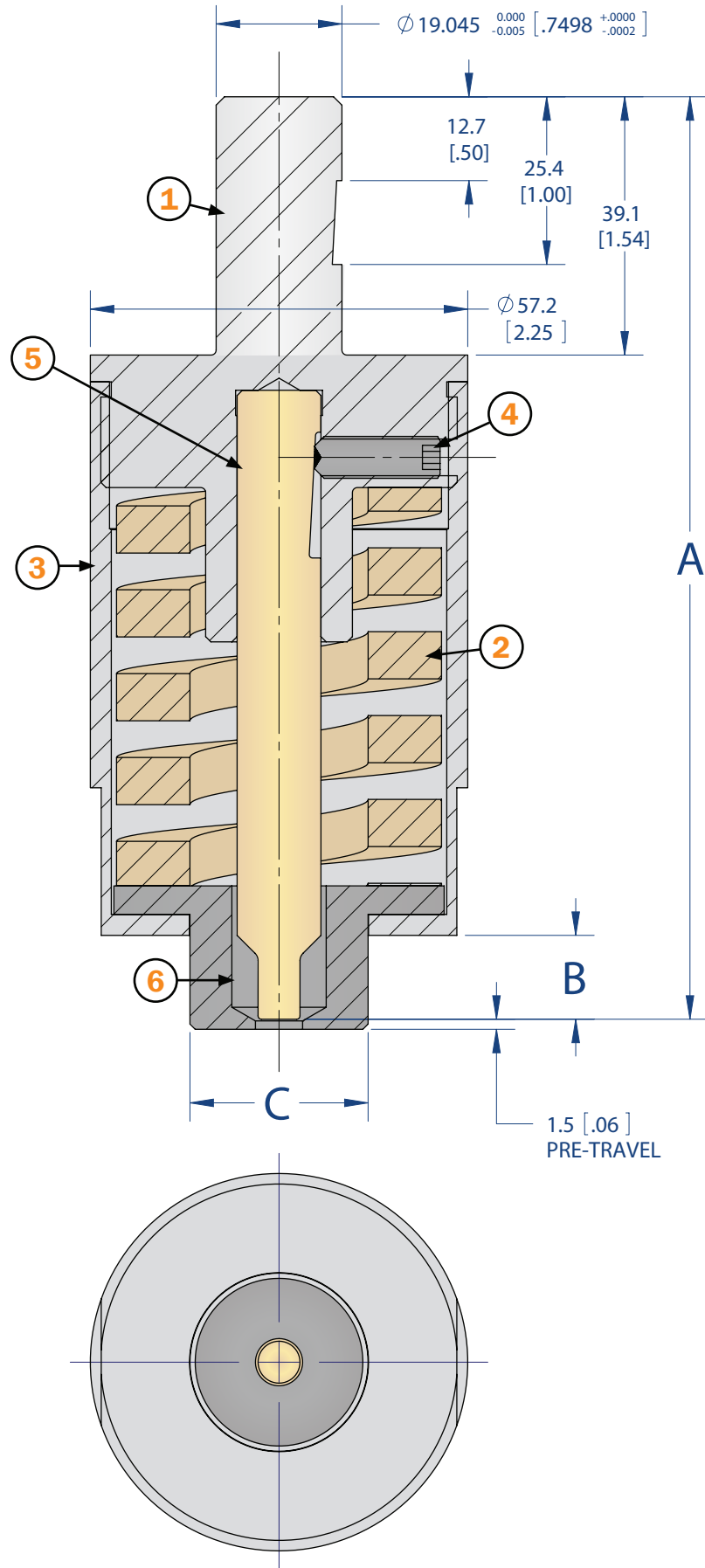

Tog-L-Loc® Ball Lock Punches

NOTE: Round (Die Set Mounting) Punch Holders come complete with a punch.
 You do not need to order a punch separately if you are ordering a Round (Die Set Mounting) Punch Holder.

THIN Punch Holders do NOT come with a punch, a punch must be ordered separately.

3.0 Ball Lock Punch

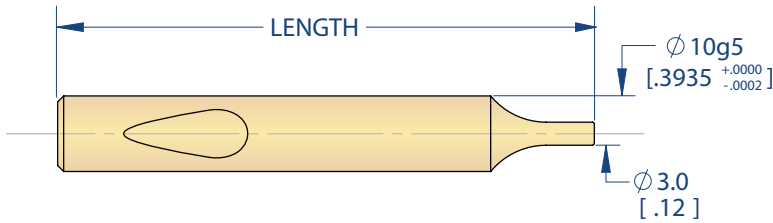

	Length		Punch Tip Radius	
	mm	in	.010	.020
Preferred	71	[2.795]	769000A	769000E
	80	[3.150]	769000B	769000F
	90	[3.543]	769000C	769000G
	100	[3.937]	769000D	769000H

Compatible Holder Styles

Die Set Mounting	p.16
THIN Holder	p.17

4.6 Ball Lock Punch

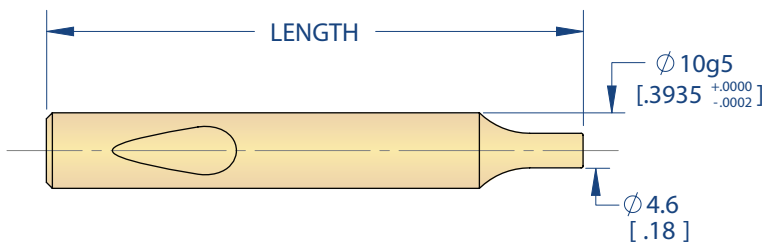

	Length		Punch Tip Radius	
	mm	in	.010	.020
Preferred	71	[2.795]	769100A	769100E
	80	[3.150]	769100B	769100F
	90	[3.543]	769100C	769100G
	100	[3.937]	769100D	769100H

Compatible Holder Styles

Die Set Mounting	p.16
THIN Holder	p.17

6.4 Ball Lock Punch

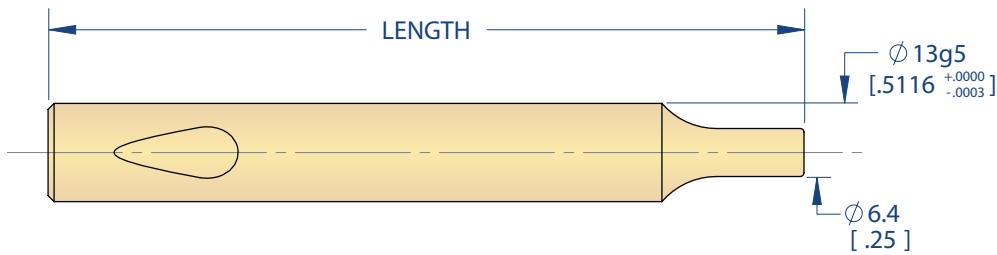

Length		Punch Tip Radius	
mm	in	.010	.020
100	[3.937]	792901A	792901C
125	[4.921]	792901B	792901D

Compatible Holder Styles

Die Set Mounting	p.16
THIN Holder	p.17

7.6 Combined Ball Lock & Whistle Notch Flat Punch

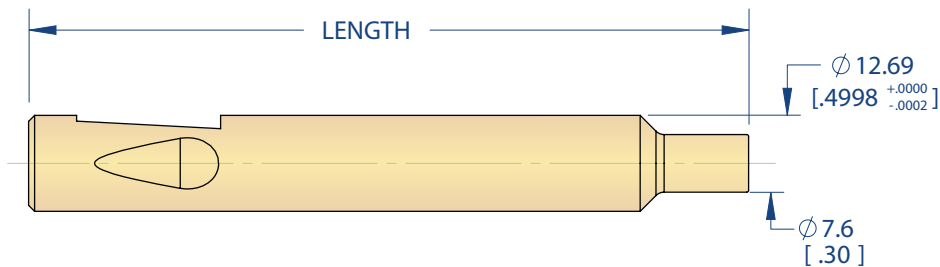

Length		Punch Tip Radius	
mm	in	.010	.020
95.25	[3.750]	768001A	768001B
120.65	[4.750]	768001C	768001D

Tog-Loc® Round (Die Set Mounting) Holders for Ball Lock Punches

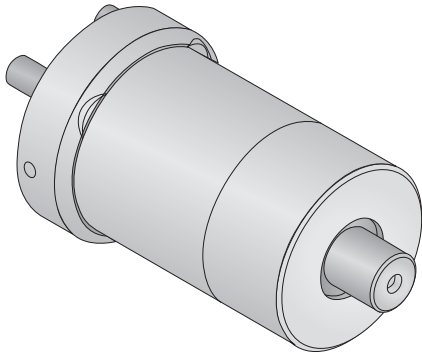

ASSEMBLY INCLUDES:

- ① One (1) Punch Holder
- ② One (1) Stripper Spring
- ③ One (1) Stripper Can
- ④ One (1) Ball & Retaining Spring
- ⑤ One (1) Dowel Pin
- ⑥ Three (3) Mounting Screws
- ⑦ One (1) Ball Lock Punch
- ⑧ One (1) Stripper Tip

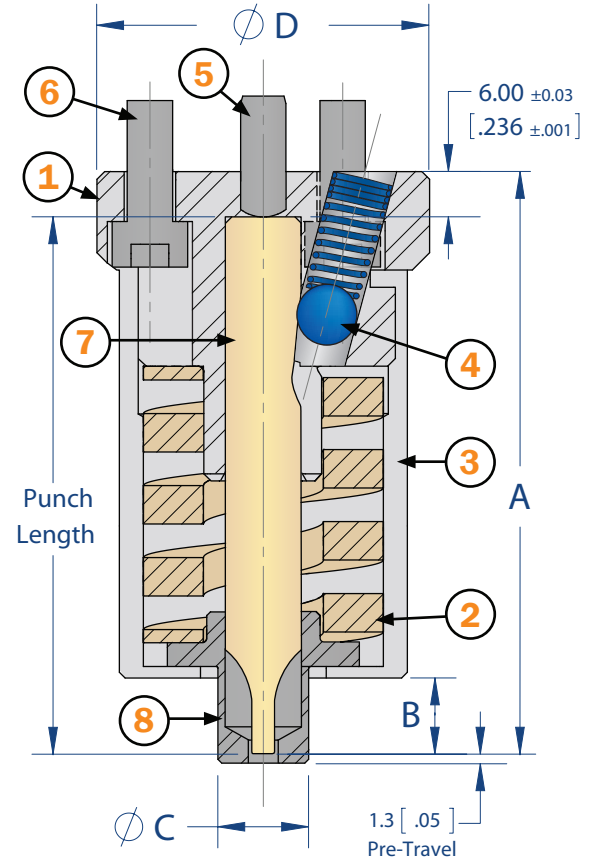

Tooling	Punch Length	A	B	C	D
3.0	71 [2.795"]	77.0 [3.031"]	10.0 [.39"]	Ø12.0 [.47"]	Ø44 [1.73"]
	80 [3.150"]	86.0 [3.386"]	19.0 [.75"]		
	90 [3.543"]	96.0 [3.780"]	29.0 [1.14"]		
	100 [3.937"]	106.0 [4.173"]	39.0 [1.54"]		
4.6	71 [2.795"]	77.0 [3.031"]	10.0 [.39"]	Ø16.0 [.63"]	Ø44 [1.73"]
	80 [3.150"]	86.0 [3.386"]	19.0 [.75"]		
	90 [3.543"]	96.0 [3.780"]	29.0 [1.14"]		
	100 [3.937"]	106.0 [4.173"]	39.0 [1.54"]		
6.4	100 [3.937"]	106.0 [4.173"]	12.0 [.47"]	Ø22.0 [.87"]	Ø57 [2.25"]
	125 [4.921"]	131.0 [5.157"]	37.0 [1.46"]		
	E	F	G	H	
3.0	11.5 [.453"]	10.5 [.413"]	15.0 [.591"]	12.500 [.4921"]	
4.6	11.5 [.453"]	10.5 [.413"]	15.0 [.591"]	12.500 [.4921"]	
6.4	14.5 [.571"]	13.0 [.512"]	19.5 [.768"]	19.500 [.7677"]	

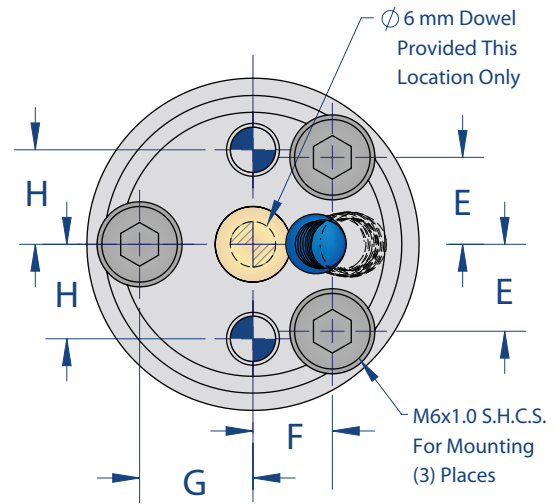

Tooling Size		Punch Length									
		71mm [2.795"]		80mm [3.150"]		90mm [3.543"]		100mm [3.937"]		125mm [4.921"]	
		.010 PTR	.020 PTR	.010 PTR	.020 PTR	.010 PTR	.020 PTR	.010 PTR	.020 PTR	.010 PTR	.020 PTR
3.0	SS20 Assembly	772100A	772100B	772100C	772100D	772100E	772100F	772100G	772100H	N/A	N/A
4.6	SS20 Assembly	772200A	772200B	772200C	772200D	772200E	772200F	772200G	772200H	N/A	N/A
6.4	SS30 Assembly	N/A						792900A	792900C	792900B	792900D

PTR = Punch Tip Radius

Tog-Loc® Thin Holder for Ball Lock Punches

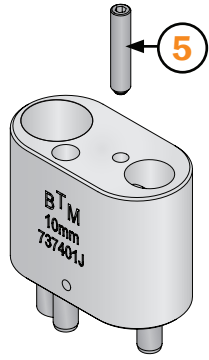

ASSEMBLY INCLUDES:

- ① One (1) Punch Holder
- ② Two (2) Dowel Pin
- ③ One (1) Mounting Screw
- ④ One (1) Ball & Retaining Spring
- ⑤ One (1) Ball Release Set Screw

NOT INCLUDED

- One (1) Punch (see p. 14-15)
- One (1) Urethane Stripper

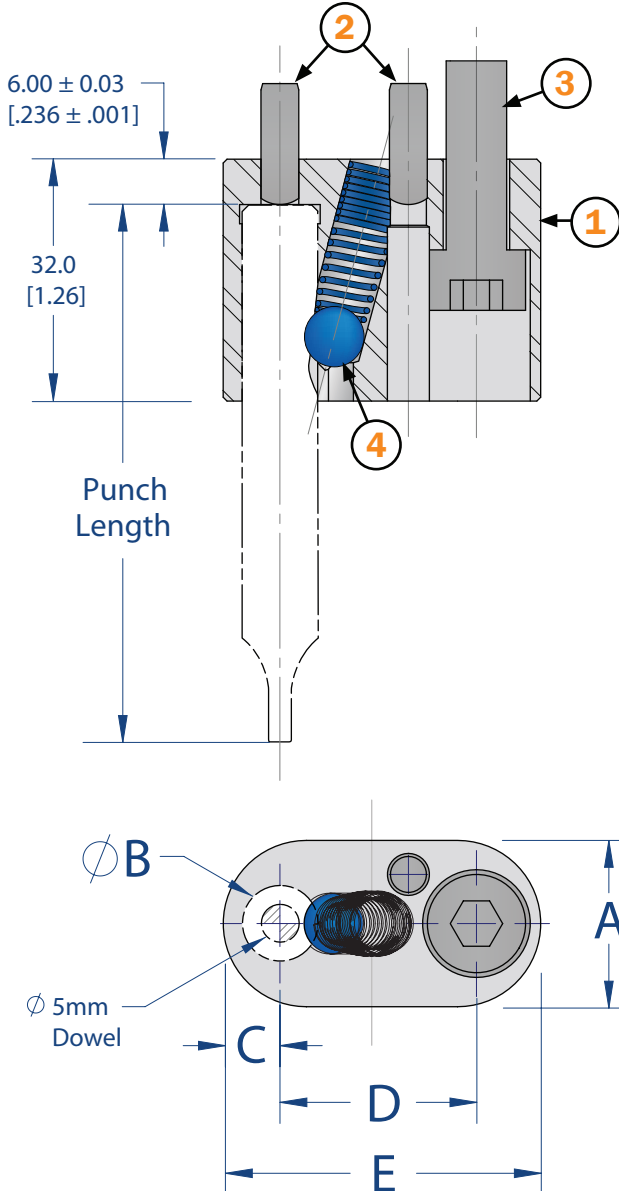

Urethane Strippers

Designed for low volume applications

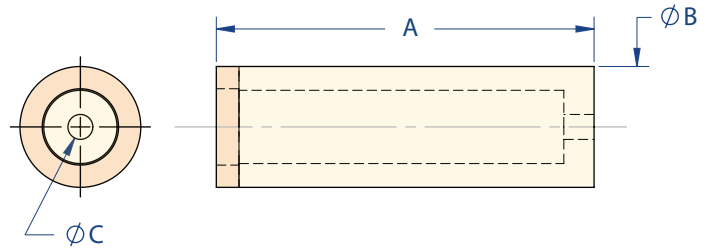

3.0 Tooling

Punch Length	A	B	C	BTM Order No.
71 [2.795"]	50.01 [1.969"]	Ø 16.0 [.63 +.000 -.015]	Ø3.30 [.130]	737413B
80 [3.150"]	59.00 [2.323"]			737414B
90 [3.543"]	69.01 [2.717"]			737415B
100 [3.937"]	78.99 [3.110"]			737416B

4.6 Tooling

Punch Length	A	B	C	BTM Order No.
71 [2.795"]	50.01 [1.969"]	Ø 20.0 [.79 +.000 -.015]	Ø4.83 [.190]	737404D
80 [3.150"]	59.00 [2.323"]			737405D
90 [3.543"]	69.01 [2.717"]			737406D
100 [3.937"]	78.99 [3.110"]			737407D

6.4 Tooling

Punch Length	A	B	C	BTM Order No.
100 [3.937"]	78.99 [3.110"]	Ø 33.0 [1.30 +.000 -.015]	Ø6.60 [.260]	737406F
125 [4.921"]	103.99 [4.094"]			737407F

Tooling Size

Tooling Size	A	B	C	D	E	BTM Order No.
3.0	22.0±0.4 [.87"±.015]	Ø10H6	7.5 [.30"]	26.00 [1.024"]	42.0 [1.65"]	737400J
4.6	22.0±0.4 [.87"±.015]	Ø10H6	7.5 [.30"]	26.00 [1.024"]	42.0 [1.65"]	737400J
6.4	26.0±0.4 [1.02"±.015]	Ø13H6	9.5 [.37"]	27.50 [1.083"]	46.0 [1.81"]	737400K

Style "A" Die

AD	Standard
.020	013741
.025	012744
.030	006709
.035	006711
.040	006713
.045	006715
.050	006717
.055	006719
.060	006721

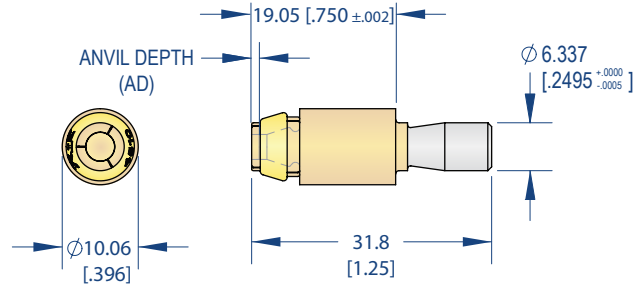

Short Insert Die

AD	Standard
.020	013743
.025	013311
.030	013312
.035	013313
.040	013314
.045	013315
.050	013316

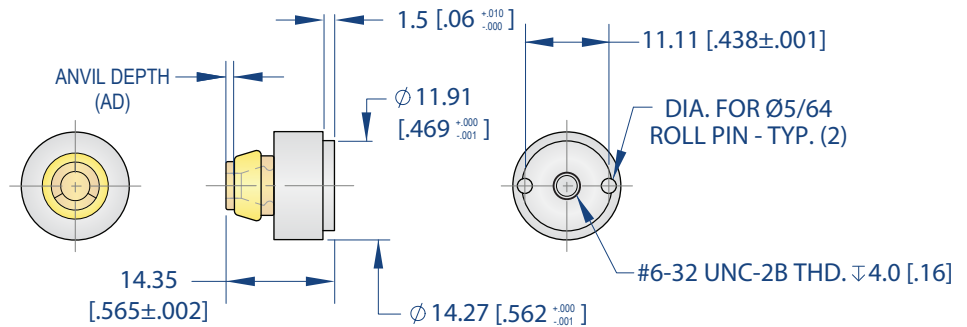

Style "A" Two Bladed Die

AD	Standard
.020	021169
.025	021170
.030	021171
.035	021172
.040	021183
.045	021184
.050	021185

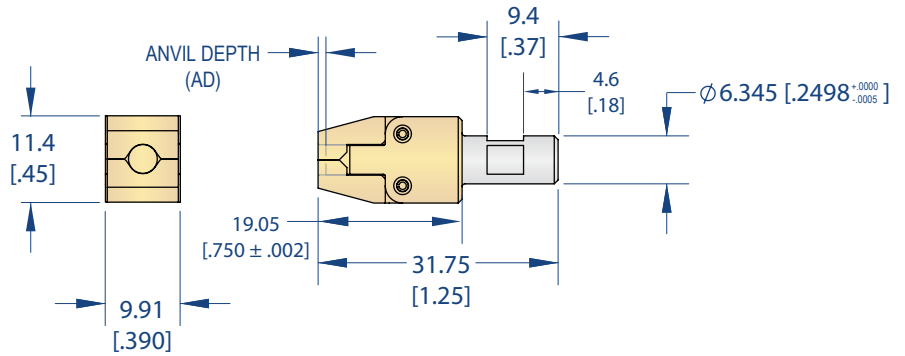

Two Bladed Combo Block Die

AD	Standard
.020	013766
.025	013767
.030	013768
.035	013769
.040	013770
.045	013771
.050	013772

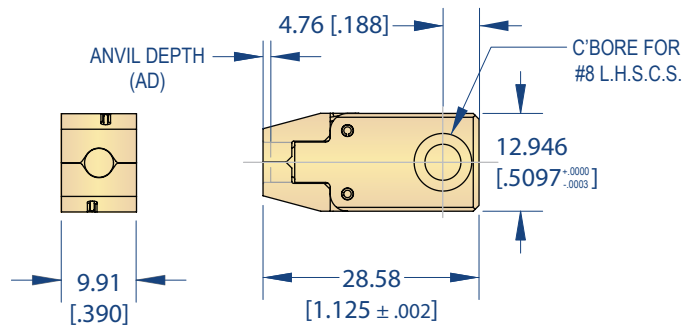

Handheld Two Bladed Combo Block Die

AD	Standard
.020	014410
.025	014411
.030	014412
.035	014413
.040	014414
.045	014415
.050	014416

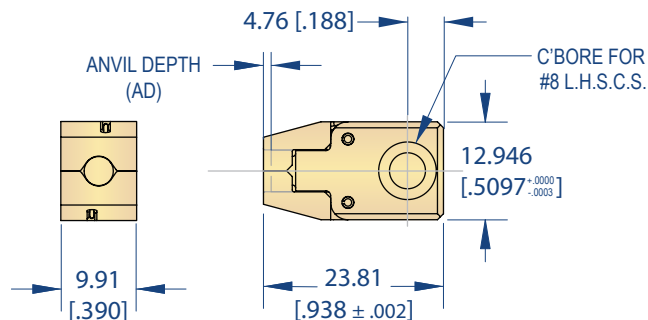

3.8

Tog-Loc® Three Blade Elastomer Dies

Style "A" Die

AD	Standard
.020	796900B
.025	796900C
.030	796900D
.035	796900E
.040	796900F
.045	796900G
.050	796900H
.055	796900J

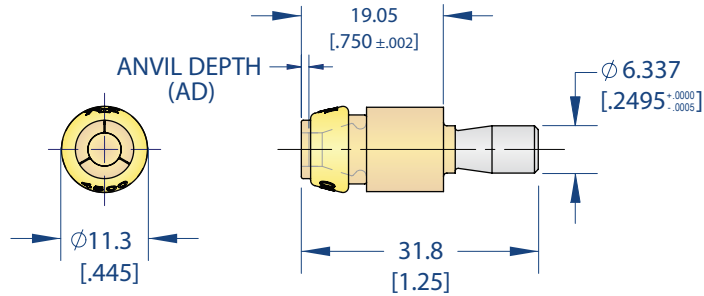

Short Insert Die

AD	Standard
.020	PD217300B
.025	PD217300C
.030	PD217300D
.035	PD217300E
.040	PD217300F
.045	PD217300G
.050	PD217300H
.055	PD217300J

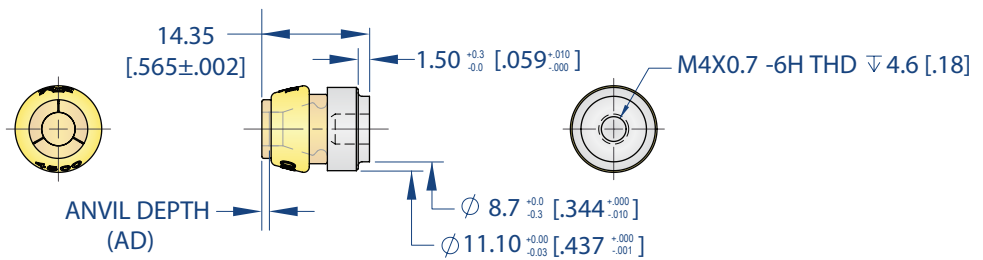

3.8 Tog-Loc® Two Bladed Die

Style "A" Two Bladed Die

AD	Standard
.020	PD204200B
.025	PD204200C
.030	PD204200D
.035	PD204200E
.040	PD204200F
.045	PD204200G
.050	PD204200H
.055	PD204200J

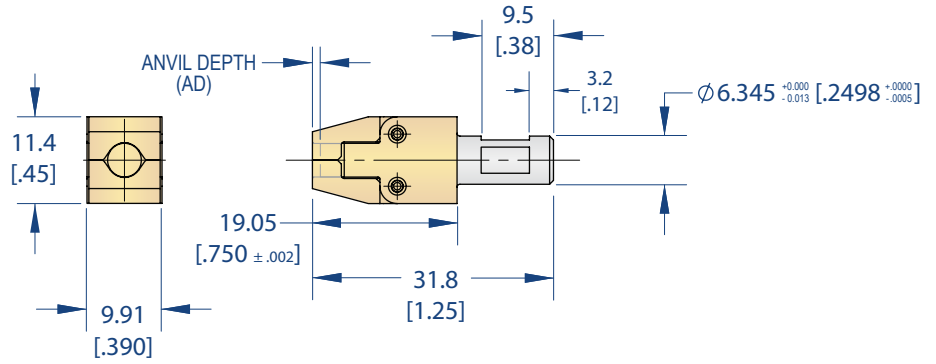

4.6

Tog-Loc® Three Blade Elastomer Dies

Style "A" Die

AD	Standard	Aluminum
.020	003933	N/A
.025	003940	019387
.030	003947	017897
.035	003954	017898
.040	003961	017899
.045	003969	017900
.050	003977	017901
.055	004037	017902
.060	006601	017903

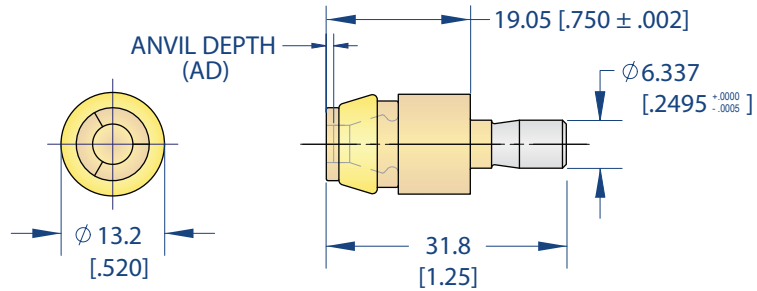

Short Insert Die

AD	Standard	Aluminum
.025	018062	N/A
.030	013264	017917
.035	013265	017918
.040	013266	017919
.045	013267	017920
.050	013268	017921
.055	013269	017922
.060	013270	017923

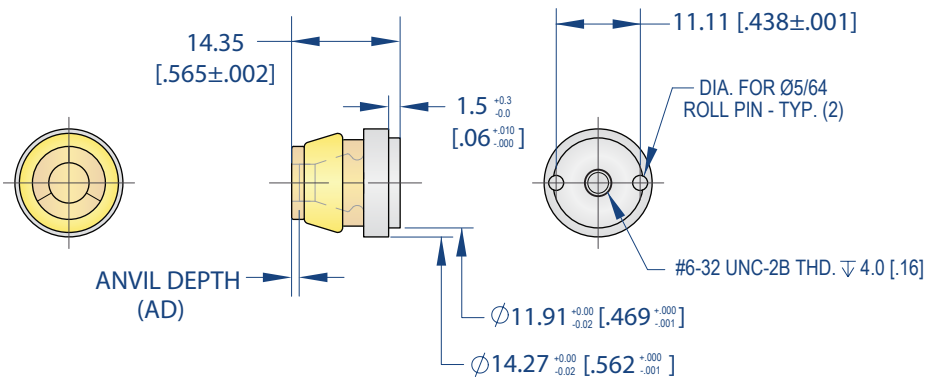

4.6 Tog-Loc® Two Bladed Dies

Style "A" Two Bladed Die

AD	Standard
.030	014858
.035	014859
.040	014860
.045	014861
.050	014862
.055	014863
.060	014864

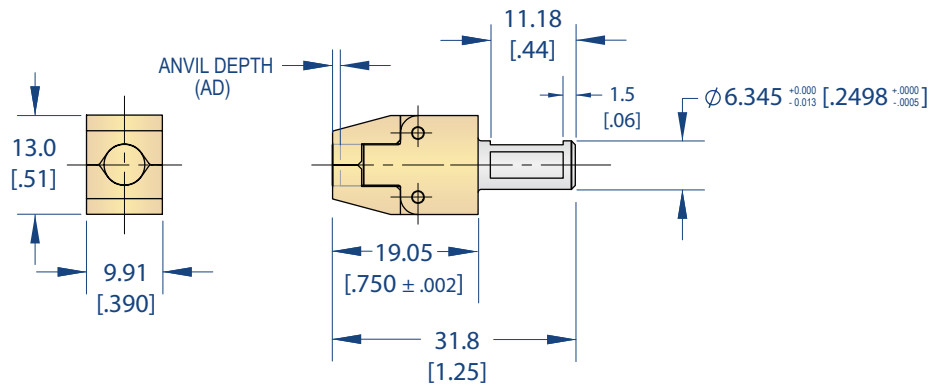

Two Bladed Combo Block Die

AD	Standard
.025	017556
.030	013405
.035	013406
.040	013407
.045	013408
.050	013409
.055	013410
.060	013411

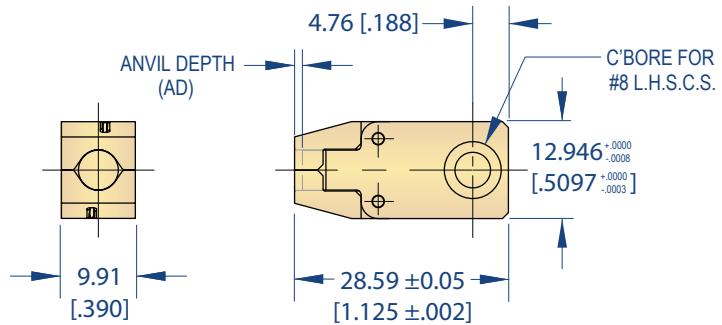

5.5

Tog-L-Loc® Three Blade Elastomer Dies

Style "A" Die

AD	Standard
.025	739100B
.030	739100C
.035	739100D
.040	739100E
.045	739100F
.050	739100G
.055	739100H
.060	739100J
.065	739100K
.070	739100L

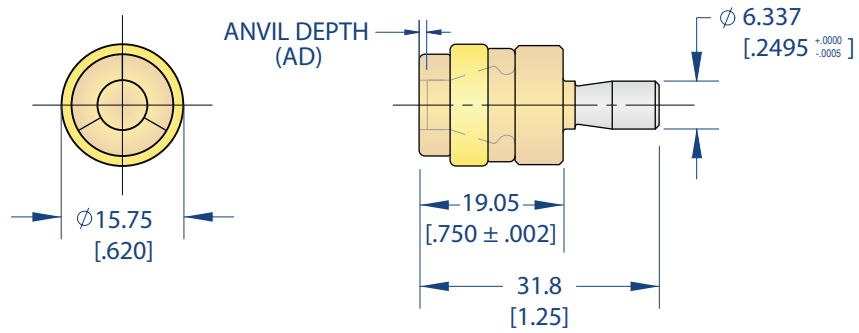

Short Insert Die

AD	Standard
.025	742200B
.030	742200C
.035	742200D
.040	742200E
.045	742200F
.050	742200G
.055	742200H
.060	742200J
.065	742200K
.070	742200L

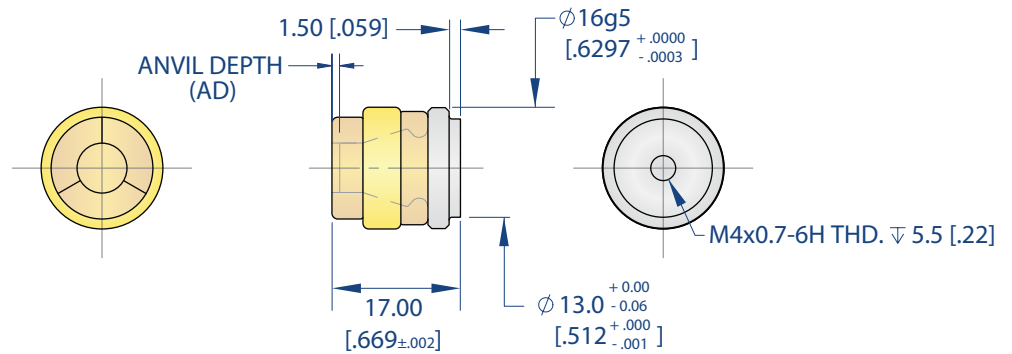

5.5 Tog-Loc® Two Bladed Die

Style "A" Two Bladed Die

AD	Standard
.025	PD239200B
.030	PD239200C
.035	PD239200D
.040	PD239200E
.045	PD239200F
.050	PD239200G
.055	PD239200H
.060	PD239200J
.065	PD239200K
.070	PD239200L

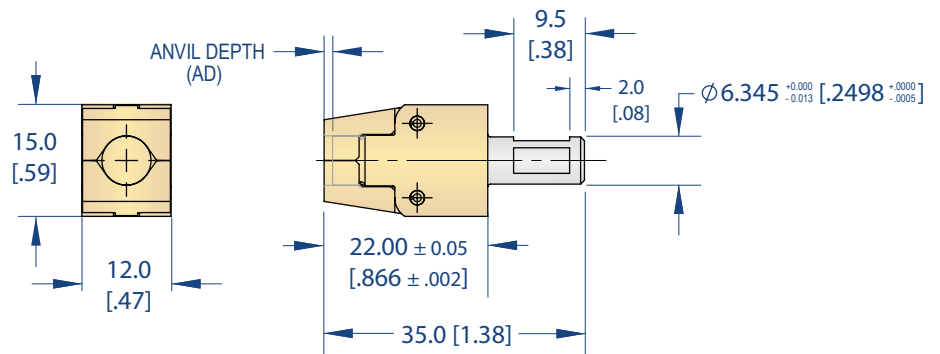

6.4

Tog-L-Loc® Three Blade Elastomer Dies

Style "A" Die

AD	Standard	Aluminum
.020	016124	018309
.025	016125	018310
.030	013908	018311
.035	013909	018312
.040	013910	018313
.045	013911	018314
.050	013912	018315
.055	013913	018316
.060	013914	018317
.065	013915	018318
.070	013916	018319
.075	013917	018320
.080	013918	018321
.085	013919	N/A
.090	013920	N/A

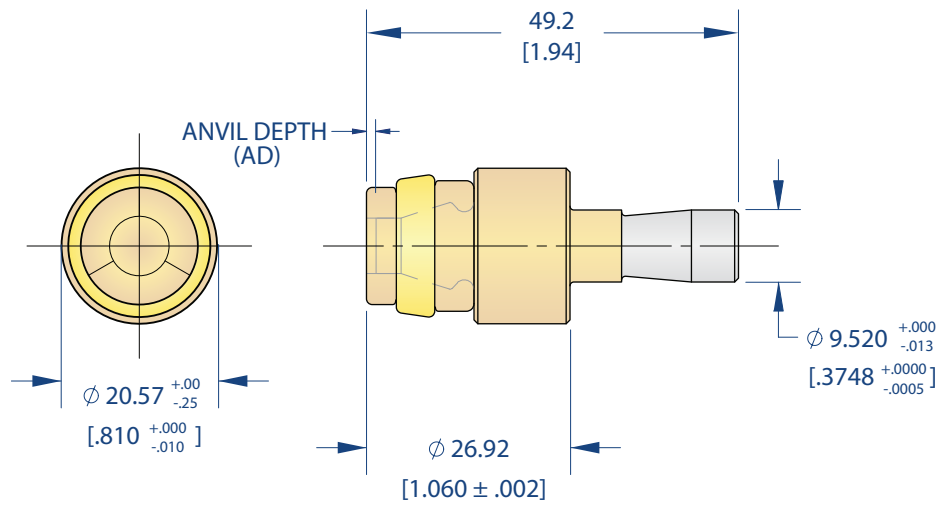

Short Insert Die

AD	Standard	Aluminum
.025	017460	018178
.030	015072	018179
.035	015073	018180
.040	015074	018181
.045	015075	018182
.050	015076	018183
.055	015077	018184
.060	015078	018185
.065	015079	018186
.070	015080	018187
.075	N/A	018188
.080	017308	018189

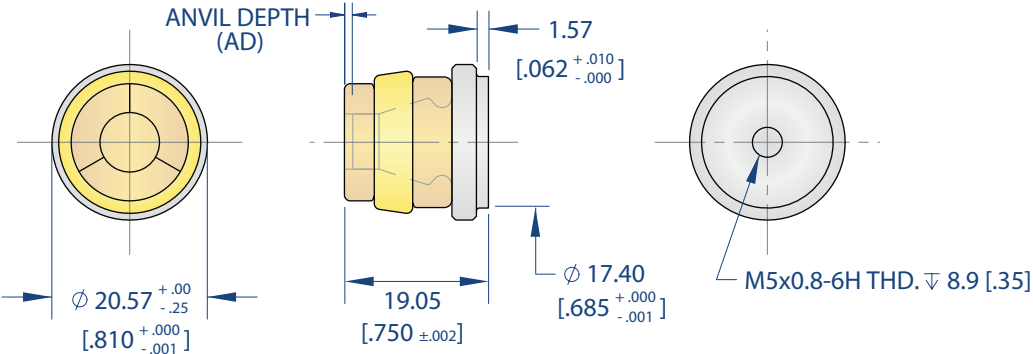

Tog-L-Loc® Three Blade Elastomer Die Holders

Style "A" Die Holders - For Three Blade Elastomer style "A" dies.

3.0
3.8
4.6

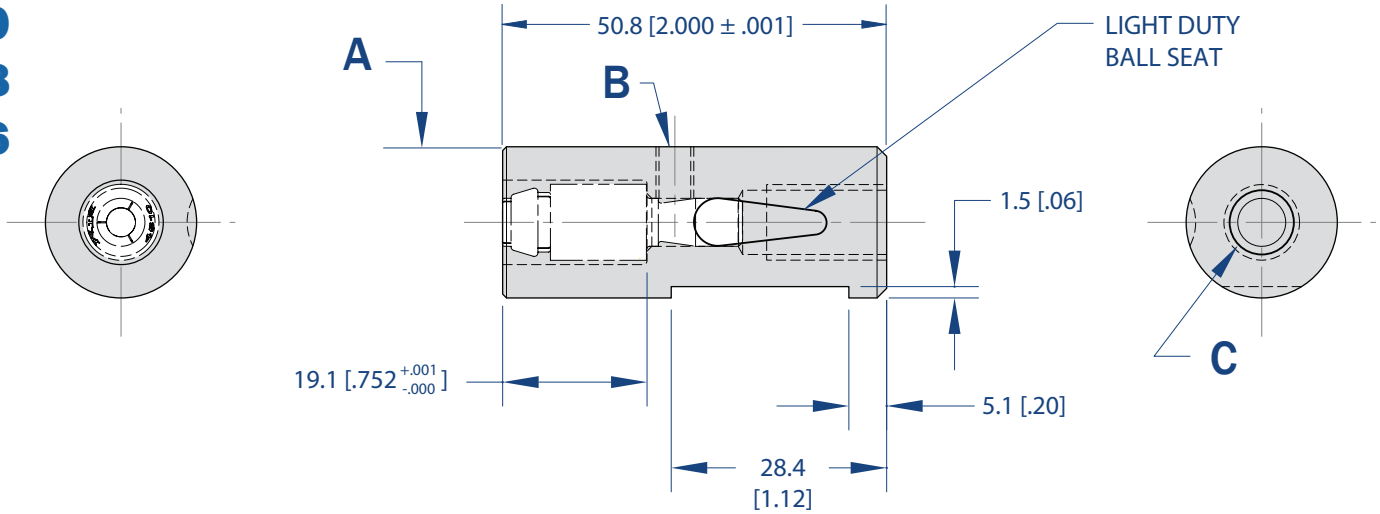

Tooling Size	Mounting Type	A	B	C	Order No.
3.0	Metric	Ø 20H6 [.7874" ^{+0.000} / _{-.0005}]	M5x0.8-6H TAP	M10x1.5 THD-6H ~ 15.8 [.62"] DP.	018891
	Imperial	Ø 19.042 [.7497" ^{+0.000} / _{-.0004}]	#10-32 UNF-2B TAP	3/8-24 UNF -2B TAP ~ 15.8 [.62"] DP.	013681

Tooling Size	Mounting Type	A	B	C	Order No.
3.8 4.6	Metric	Ø 20H6 [.7874" ^{+0.000} / _{-.0005}]	M5x0.8-6H TAP	M10x1.5 THD-6H ~ 15.8 [.62"] DP.	018892
	Imperial	Ø 19.042 [.7497" ^{+0.000} / _{-.0004}]	#10-32 UNF-2B TAP	3/8-24 UNF -2B TAP ~ 15.8 [.62"] DP.	007689

5.5

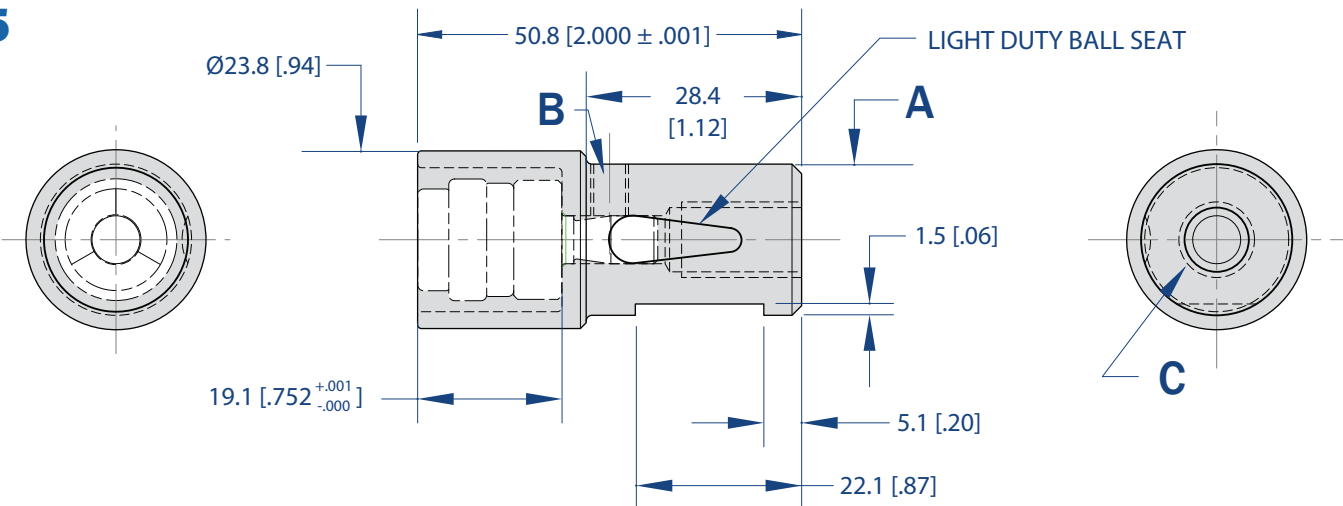

Mounting Type	A	B	C	Order No.
Metric	Ø 19.992 (.7871" ^{+0.000} / _{-.0005})	M5x0.8-6H TAP	M10x1.5 -6H TAP ~ 15.8 [.62"] DP.	018893
Imperial	Ø 19.045 (.7498" ^{+0.000} / _{-.0002})	M5x0.8-6H TAP	3/8-24 UNF -2B TAP ~ 15.8 [.62"] DP.	013888

6.4

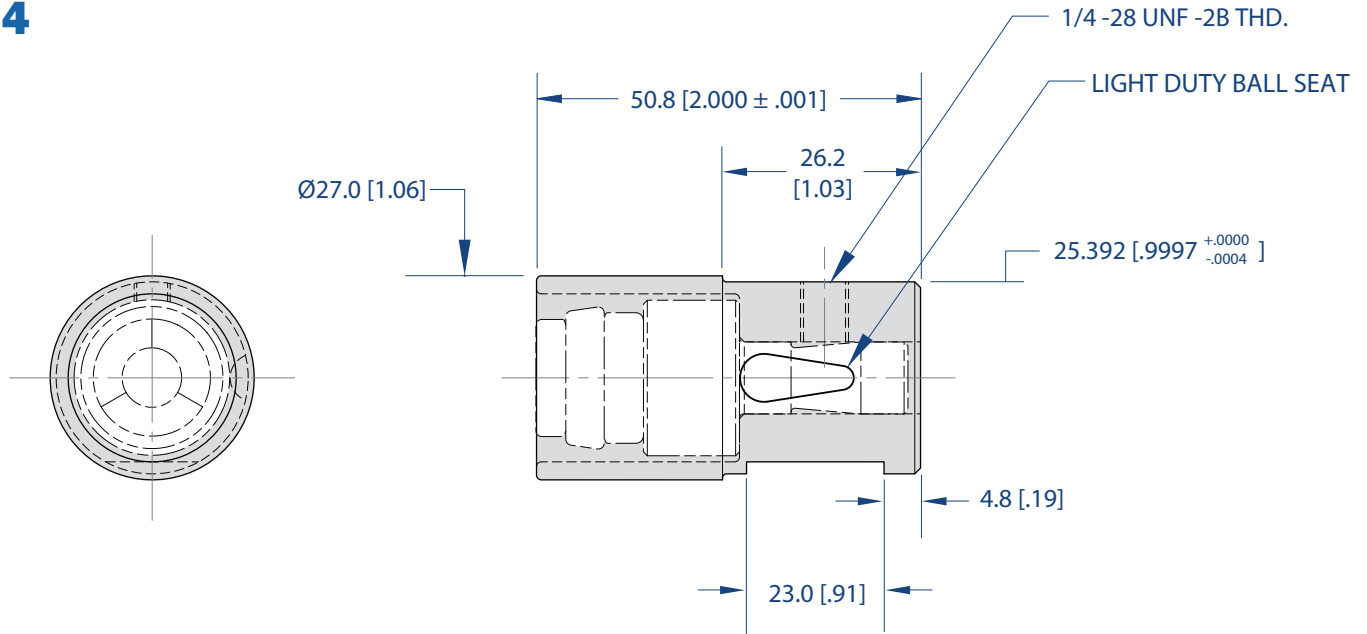

Mounting Type	A	Order No.
Imperial	6.35 (.25") -2B THD ~ 12.7 (.50) DP.	013906

Short Insert Die Holder - For Three Blade Elastomer Short Insert Dies.

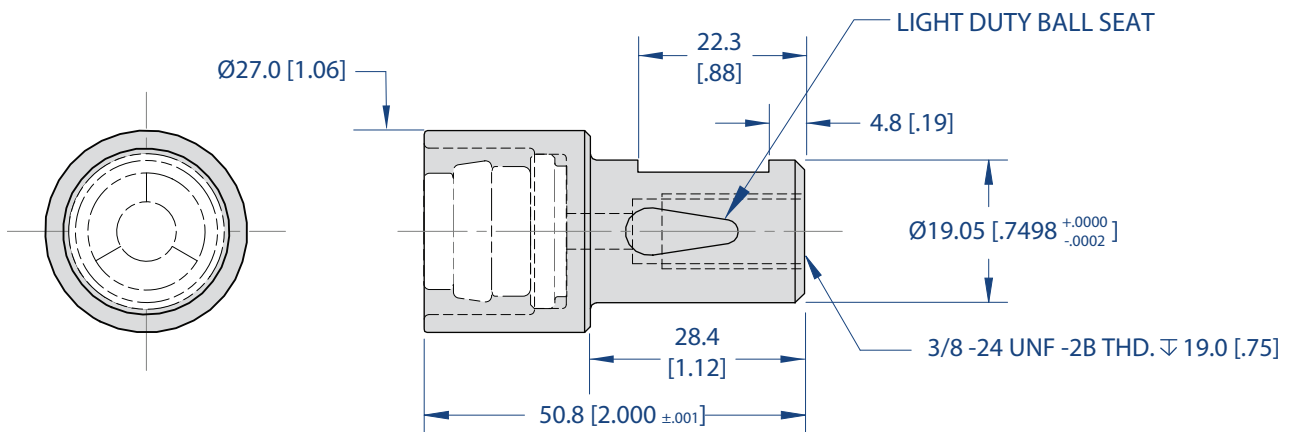

Tool Size	Mounting Type	Order No.
6.4	Imperial	015097

3 Blade Elastomer Die Assembly

The location tolerance to the centerline of the die hole should be $\pm 0.013\text{mm}$ [$\pm .0005$ "].

3 bladed Style "A" dies require a knock out hole from the back side.

3 bladed Style "A" dies should have as much perimeter guarding protecting the blades as possible.

360° of guarding is preferred, but not necessarily required. Contact BTM for more information.

GUARDING ALTERED FROM STANDARD

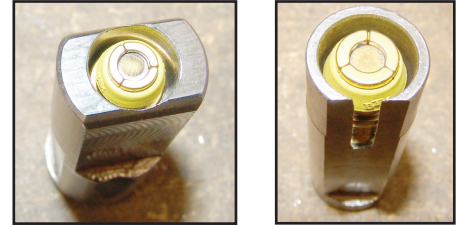

3.0 & 4.6 Short Insert Die Mounting

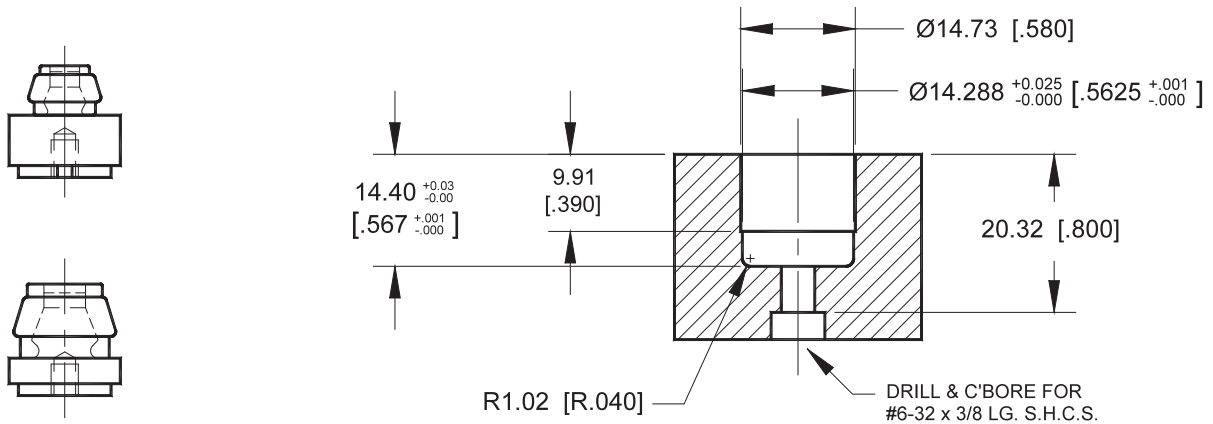

3.8 Short Insert Die Mounting

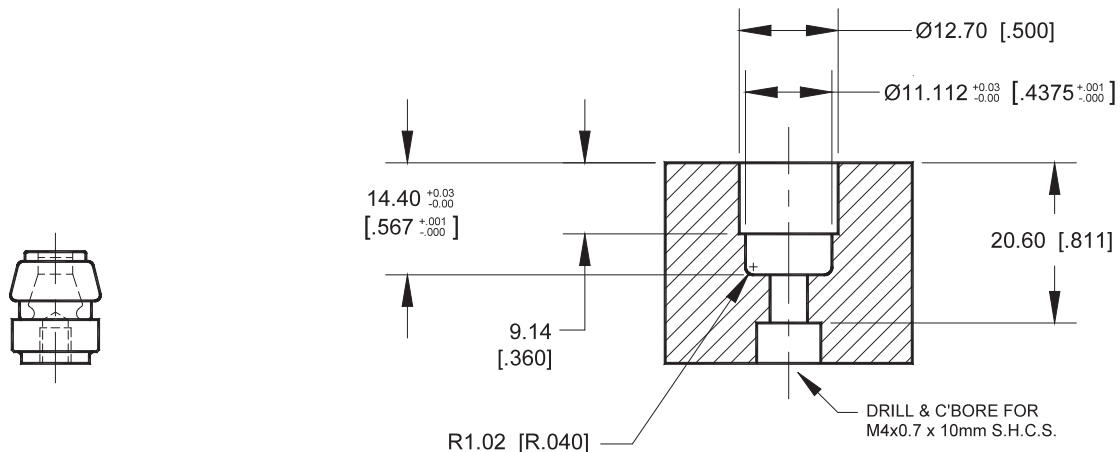

5.5 Short Insert Die Mounting

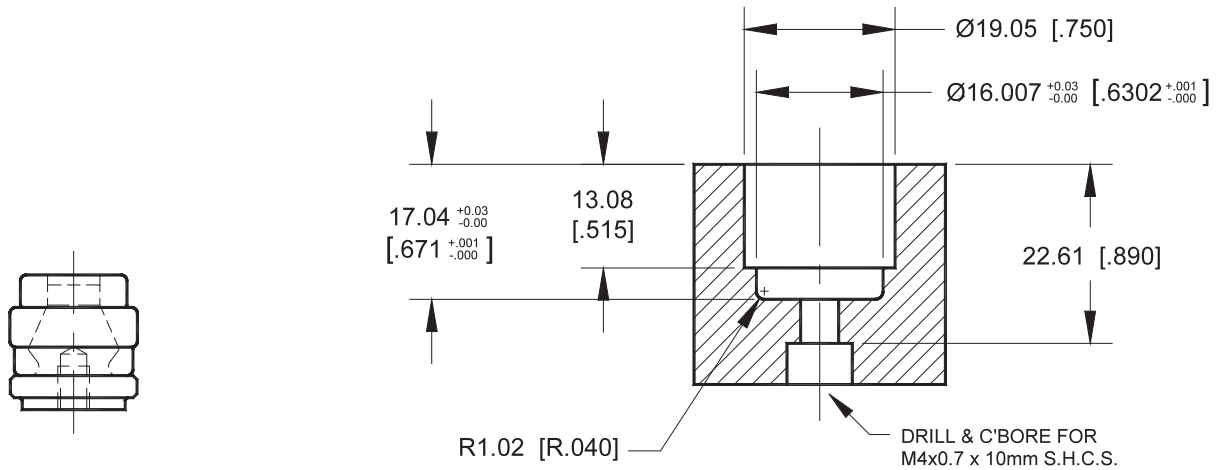

6.4 Short Insert Die Mounting

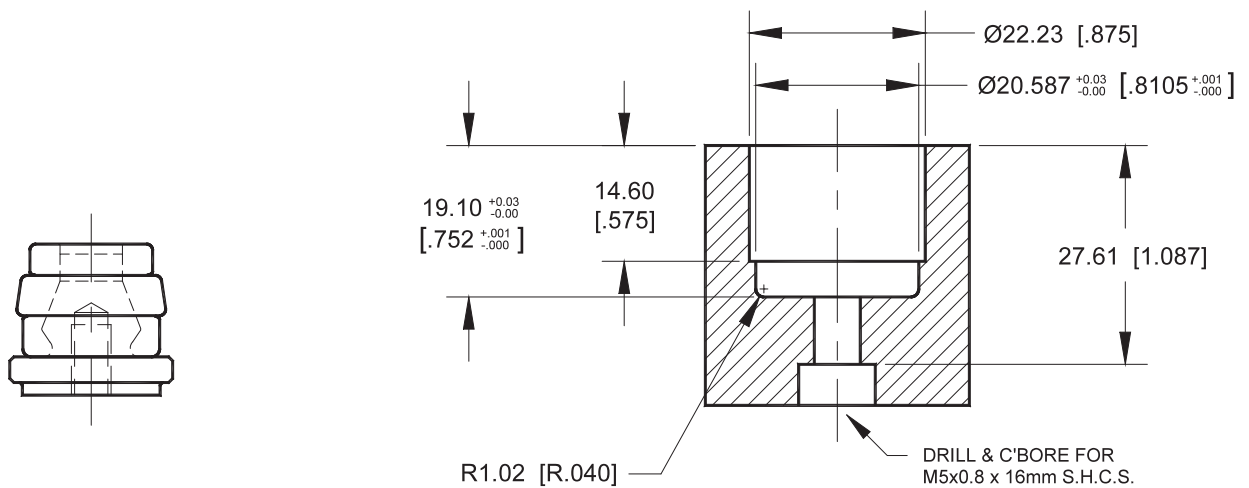

3.0 Style "A" Die Mounting

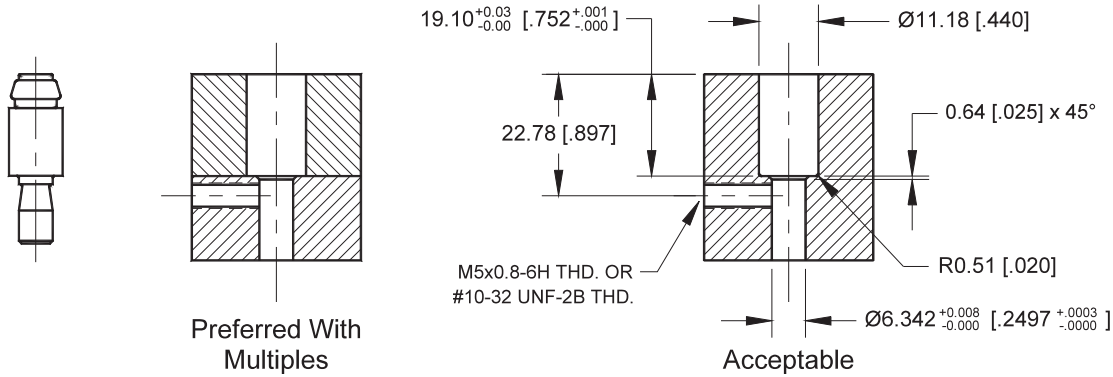

3.8 Style "A" Die Mounting

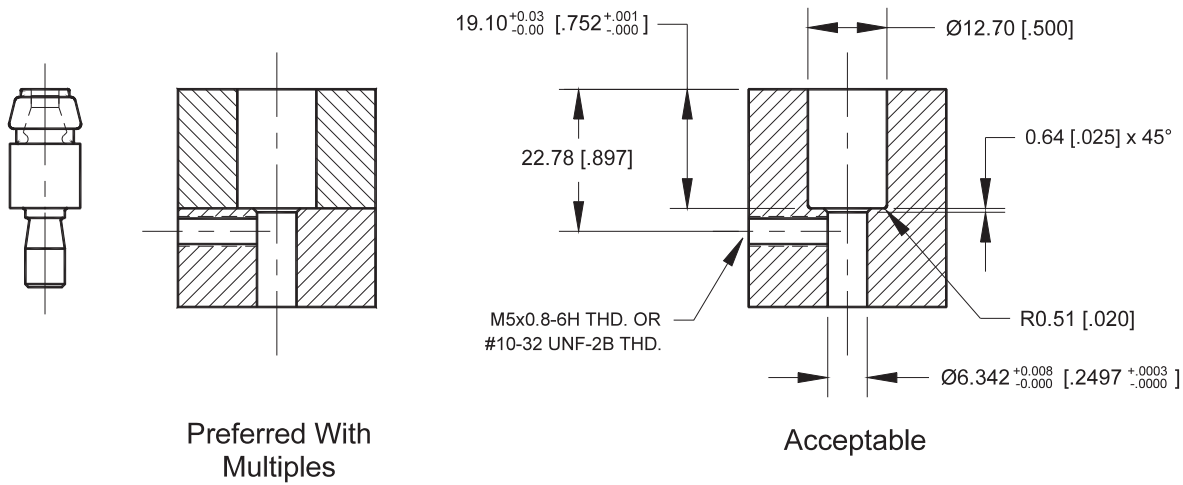

4.6 Style "A" Die Mounting

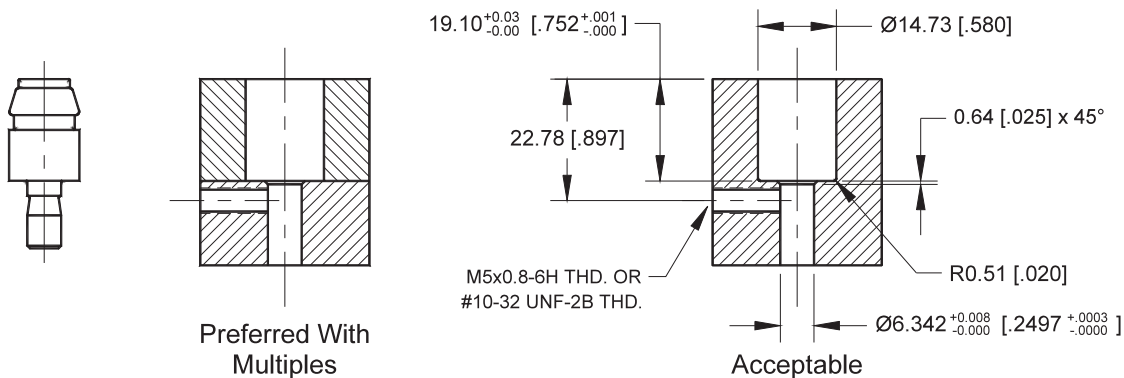

5.5 Style "A" Die Mounting

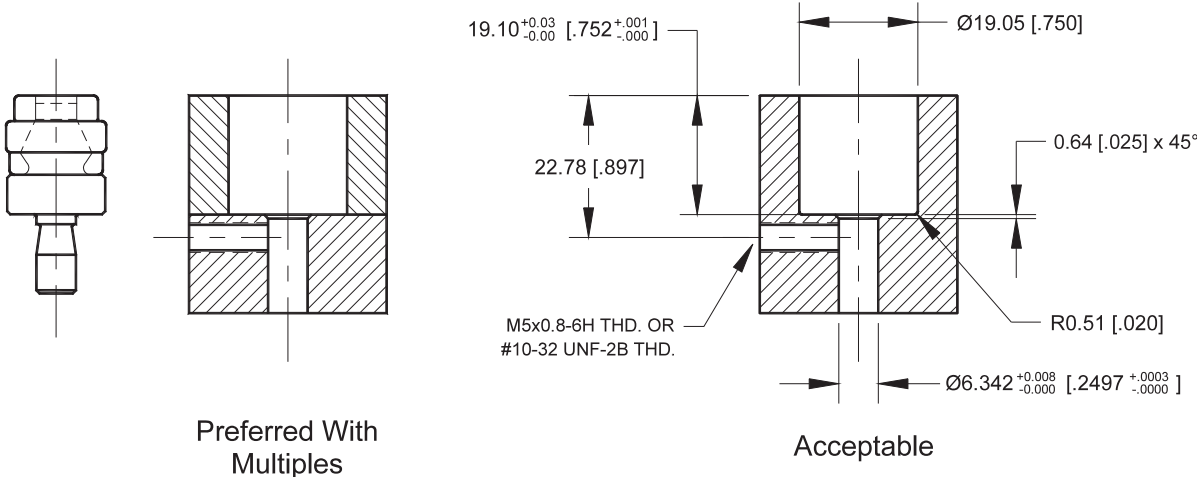

6.4 Style "A" Die Mounting

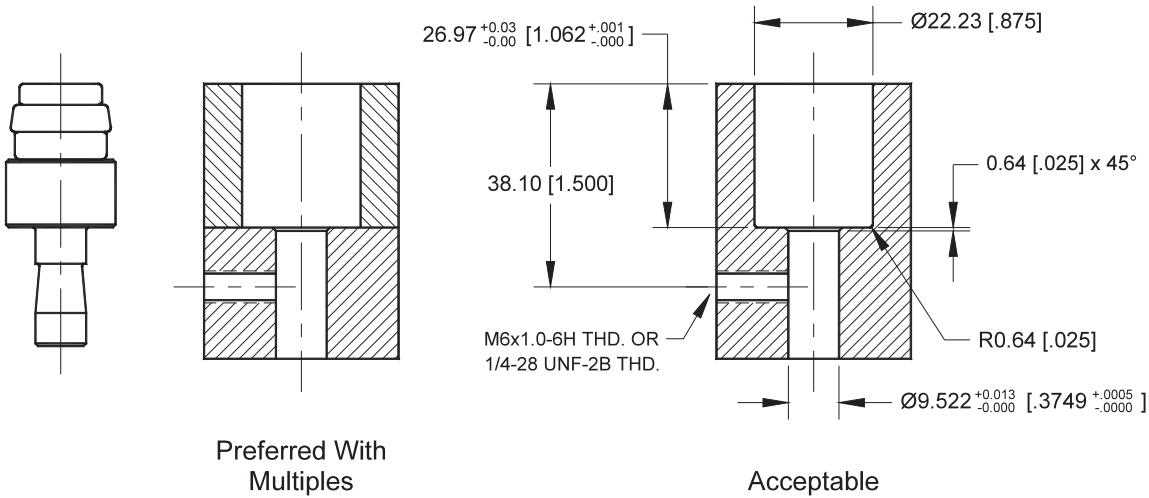

Applying Tog-L-Loc®: Tog-L-Loc® Two Blade Die Mounting Information

Two Blade Die Assembly

2 bladed dies require a clearance pocket for the blades to open freely.

The locational tolerance to the centerline of the die should be ± 0.013 [.0005"].

3.0 Style "A" Die Mounting

3.8

4.6

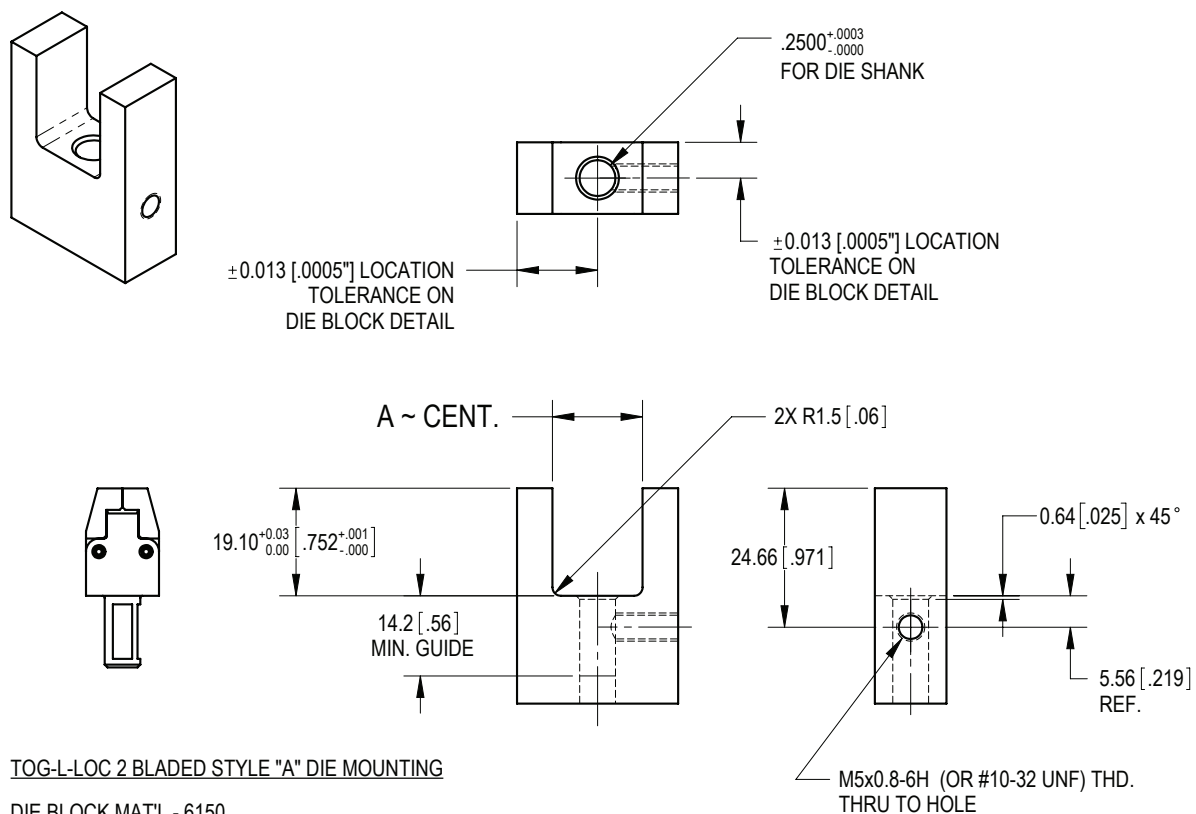

TOG-L-LOC 2 BLADED STYLE "A" DIE MOUNTING

DIE BLOCK MAT'L - 6150
DIE BLOCK HARDNESS - Rc 50-54

NOTE:

DRAWING PROVIDES DIE MOUNTING DIMENSIONS AND SPECIFICATIONS ONLY. DESIGN OF REMAINDER OF DIE BLOCK IS BASED ON SPECIFIC CUSTOMER APPLICATION.

Tooling
Size

A

3.0	14.5	$^{+0.5}_{-0.0}$	(.57"	$^{+.02}_{-.00}$)
3.8	14.5	$^{+0.5}_{-0.0}$	(.57"	$^{+.02}_{-.00}$)
4.6	16.0	$^{+0.5}_{-0.0}$	(.63"	$^{+.02}_{-.00}$)

5.5

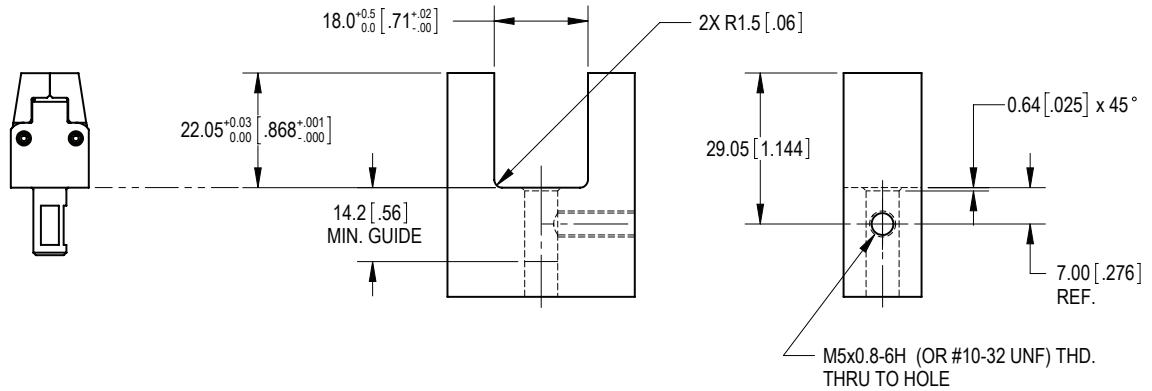
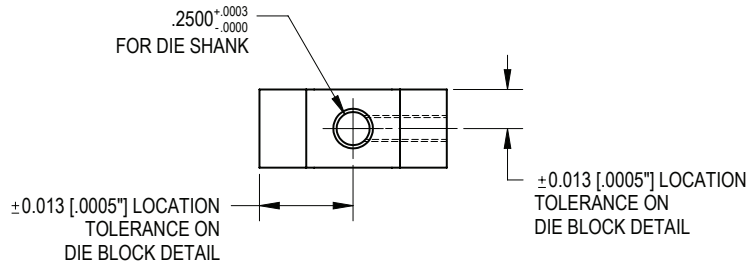
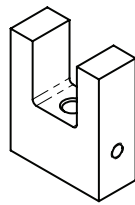

5.5 TOG-L-LOC 2 BLADED STYLE "A" DIE MOUNTING

REF. BTM DIE ASSEMBLY #PD239200A

DIE BLOCK MAT'L - 6150
DIE BLOCK HARDNESS - Rc 50-54

NOTE:

DRAWING PROVIDES DIE MOUNTING DIMENSIONS AND SPECIFICATIONS ONLY. DESIGN OF REMAINDER OF DIE BLOCK IS BASED ON SPECIFIC CUSTOMER APPLICATION.

3.0 Combo Block Mounting

4.6

A hardened die block or anvil should be used; preferably 4150HT steel.

TOP OF DIE BLADES MUST BE FLUSH WITH SURROUNDING AREA FOR PROTECTION.

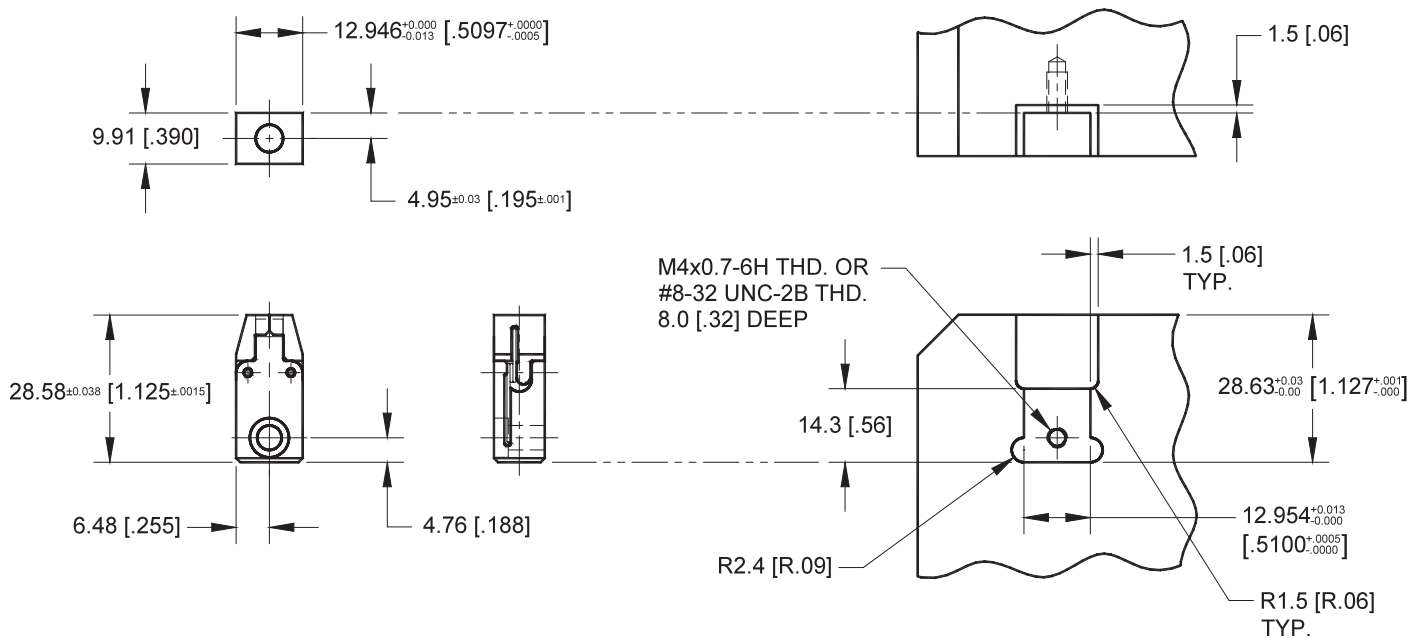



BTM has a wide range of products for applying Tog-L-Loc[®] tooling including:

Handheld Units



BTM's handheld units are an economical approach to fastening sheet metal assemblies. Pneumatic, Hydraulic, and Self-Contained Units in a variety of styles are available. The units can be set up to join a range of thicknesses or optimized for a specific metal thickness.

Die Sets



Tog-L-Loc[®] tooling can be inexpensively designed into single or compound motion die set packages.

Universal Presses



Universal presses are hydraulically operated presses that easily adapt to join a variety of parts.

Special Fixtures



Manually loaded and unloaded dedicated tooling can be built for a single part or a family of parts.

Specialized Units



BTM provides pneumatic, hydraulic, air/oil, and electrically driven units with single or dual motions for both stationary and robotic applications.

Special Systems



Achieve faster cycle times with automatic parts handling and/or by combining processes.

For more information, or to see our full line of products, please visit:

www.BTMCOMP.COM